

8 | System Protection

Course Outline

1. Introduction to WECC
2. Fundamentals of Electricity
3. Power System Overview
4. Principles of Generation
5. Substation Overview
6. Transformers
7. Power Transmission
- 8. System Protection**
- 9. Principles of System Operation**

Overview

- Purpose of Protection Systems
- Characteristics of Protection Systems
- Types of Relay and Applications

Purpose

- Then we examine how a protection system operates. The primary purpose of the protection system is to detect faults and, as rapidly as possible, "clear" faults.
- ***Faults*** are physical conditions that cause a device, component, or element to fail to perform in the required manner; for example, a short circuit or a broken wire.

Causes of Faults

- Some of the common causes of faults are:
- A tree limb comes in contact with an energized overhead wire.
- An overhead wire breaks due to snow or ice loading, or because a car strikes the utility pole causing the wire to come in contact with the ground.
- Power system components such as circuit breakers or transformers malfunction; or the insulation fails due to wear, age, or repeated operations.
- Lightning strikes an overhead wire, either causing physical damage or creating charged air molecules that serve as a path on which fault current can flow.

Protection System

- Rapid operation of the protection system accomplishes the following:
- **Maintains Safety**
 - Maintains Personnel and Public Safety. A downed wire that has not been electrically isolated is still energized. This presents a safety hazard to people who may attempt to move it or who inadvertently contact it.

Protection System

- **Prevents Damage**

- Prevents More Extensive Damage. Short circuit currents during faults are many times the normal load currents. If the flow of the current is not interrupted quickly, components of the electric system may be damaged. In addition, some faults can cause over-voltages that exceed the rating of the insulation of some components, resulting in further damage to the equipment. The overvoltage's are usually transient and are produced from simple circuit changes, such as a circuit breaker opening or the grounding of a conductor.

Protection System

- **Prevents Stability Problems**
 - Prevents Power System Stability Problems. Faults that remain on high-voltage transmission equipment or on generators can cause system stability problems. Power system stability is discussed in more detail in ***Module 9: Principles of Power System Operation.***

Characteristics

- Protection systems have three major components:
 - 1) Measuring Devices
 - 2) Protective Relays
 - 3) Control Circuitry

Measuring Devices

- Most protection systems analyze power system current flow and/or voltage to determine whether a fault exists. Sudden changes in these quantities could indicate that a fault exists.
- For example: either a sudden increase in current flow to many times the normal load current, or a significant increase or decrease in line voltage could indicate that a fault exists somewhere.
- The protection system cannot directly use the voltage and current measurements from the high-voltage equipment as inputs. Therefore, these values must be scaled down.

Measuring Devices

- The following devices perform this function:
 - current transformers (CTs)
 - voltage transformers (PTs)
 - coupling capacitance voltage transformers (CCVTs)

Current Transformer (CT)

- Power system current is measured by ***current transformers***; commonly called CTs. CTs reduce or scale down the actual current to proportional values of a few amperes for use by the protection system.
- Most CTs are donut-shaped and are installed over the bushings of power transformers, circuit breakers, or generators.

Current Transformers (CTs)

- CTs produce a small secondary current flow (a few amps) that is proportional to a larger primary current flow in the power system.
- The turns ratio of the CT may be 2500:1. This allows the current to be reduced to make it useable for metering and relays.

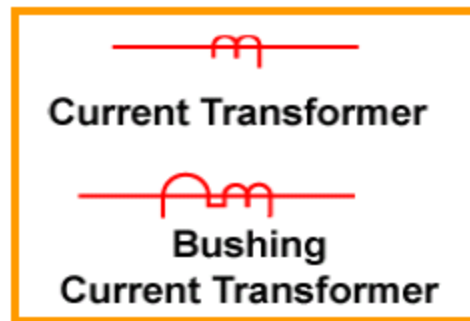

Bushing Mounted (CT)



Metering CT's

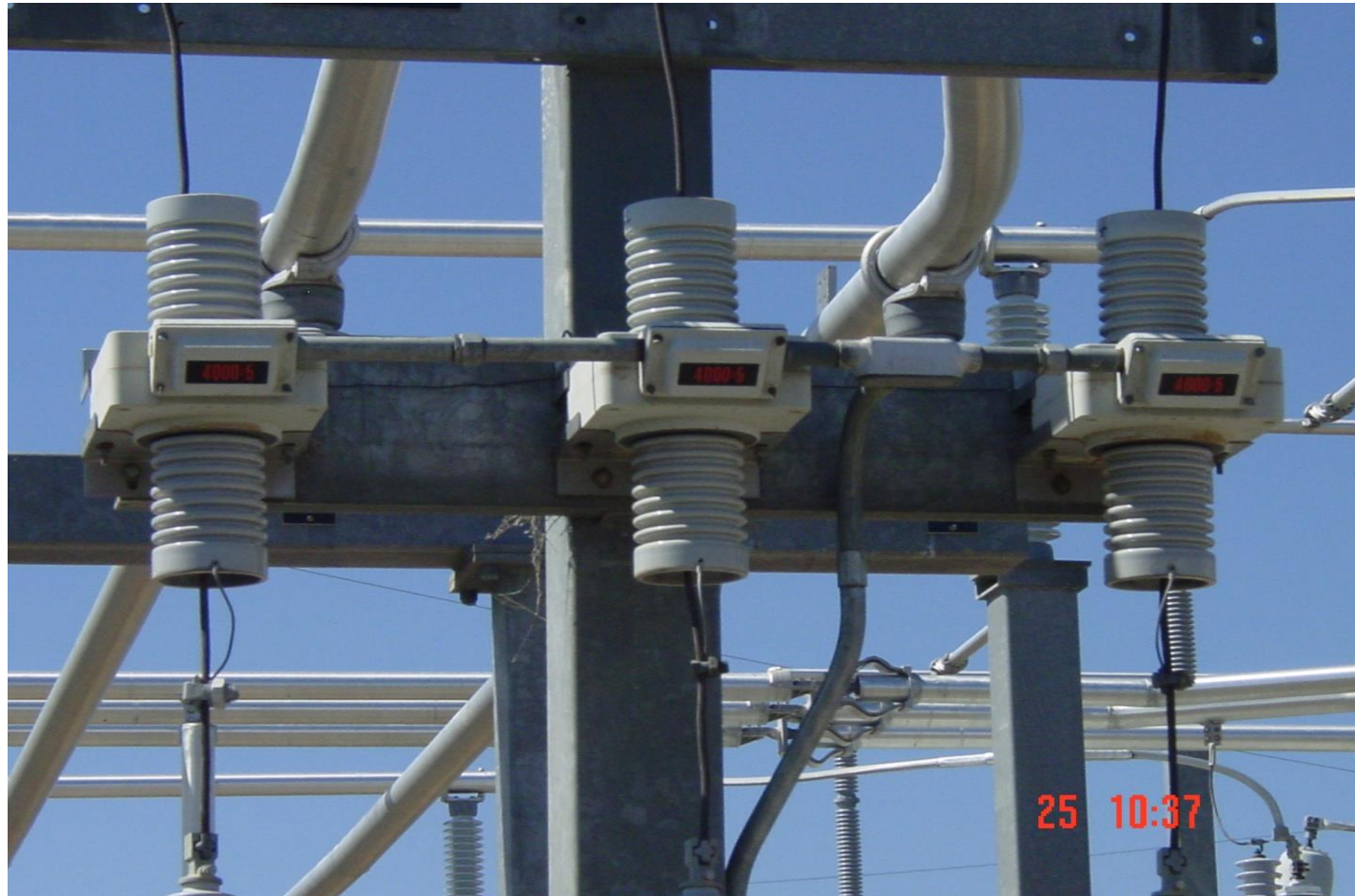



Current Transformer (External)



PT's and CCVT's

- Power system voltage is measured either by ***voltage transformers or coupling capacitance voltage transformers (CCVTs)***, depending on the voltage level being measured. Both devices reduce electric system voltage down to proportional values of 120 volts or less.
- Voltage transformers are simple magnetic core, wire-wound transformers. They are usually referred to as PTs, short for potential transformers. PTs operate in the same way as step-down power or distribution transformers.

PT's and CCVT's

- At voltage levels of 100 kV or higher, the cost of PTs becomes very high. At these voltage levels, therefore, CCVTs are typically used. A *CCVT is a stack of capacitors connected between the points of voltage measurement. The desired 120 voltage level is obtained by voltage division.*

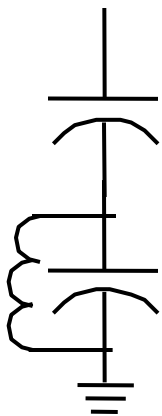

The accuracy of CCVTs is less than that of PTs. CCVTs may not be acceptable, where high accuracy is required, such as for billing or metering functions.

CCVT

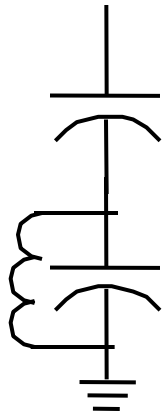

Voltage measuring
transformers

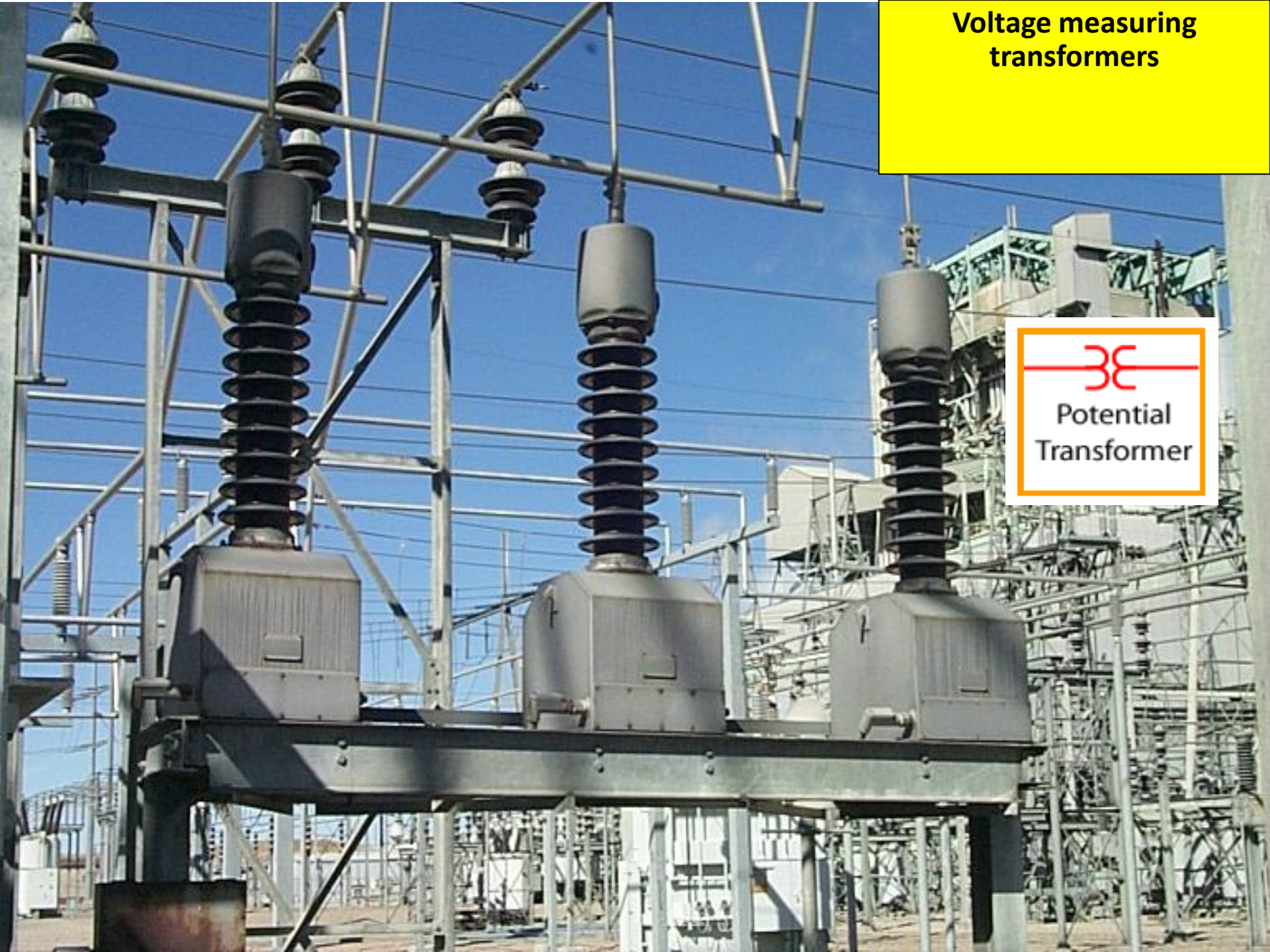

69kV PT's

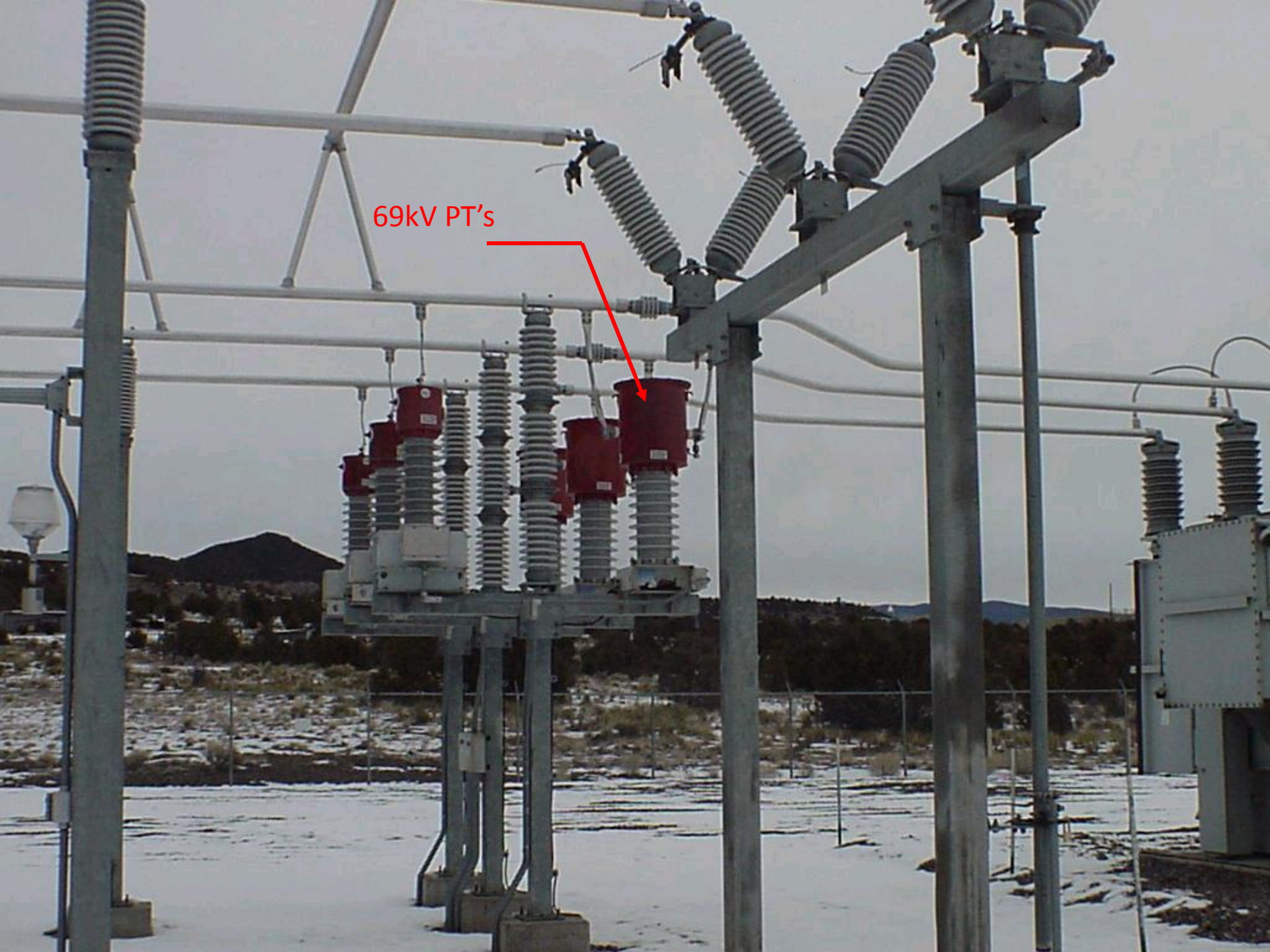
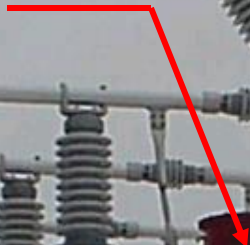

San Luis Valley 115kV Bus "B" PT's

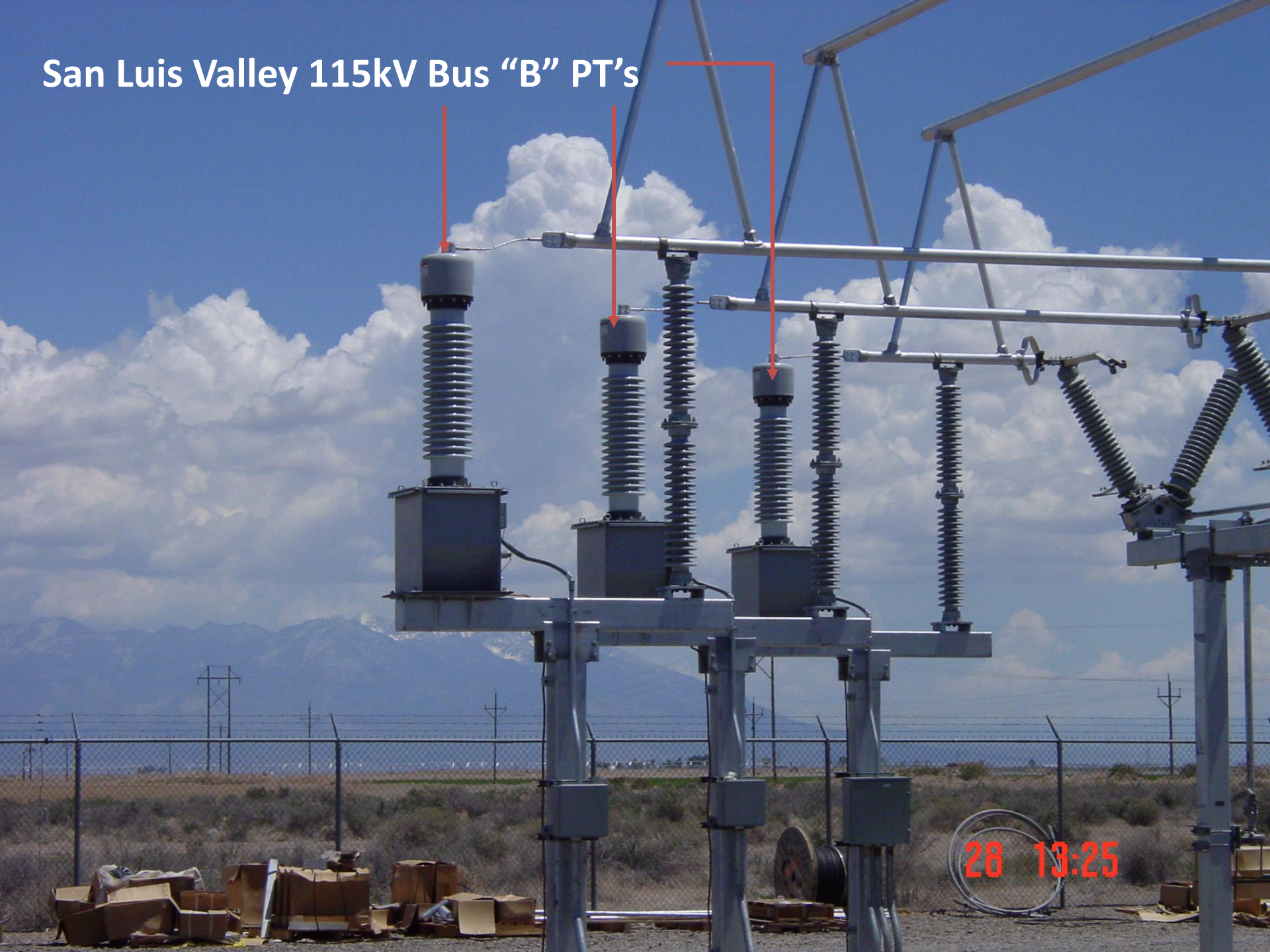

28 13:25

Protective Relays

- ***Protective relays*** are protection system devices which compare power system voltages and currents to normally-expected values to determine whether the protected device has a fault.
- The earliest types of protective relays, many of which are still in use today, were built using electromechanical components, such as gears, springs, mechanical timers, and induction disks.

Protective Relays

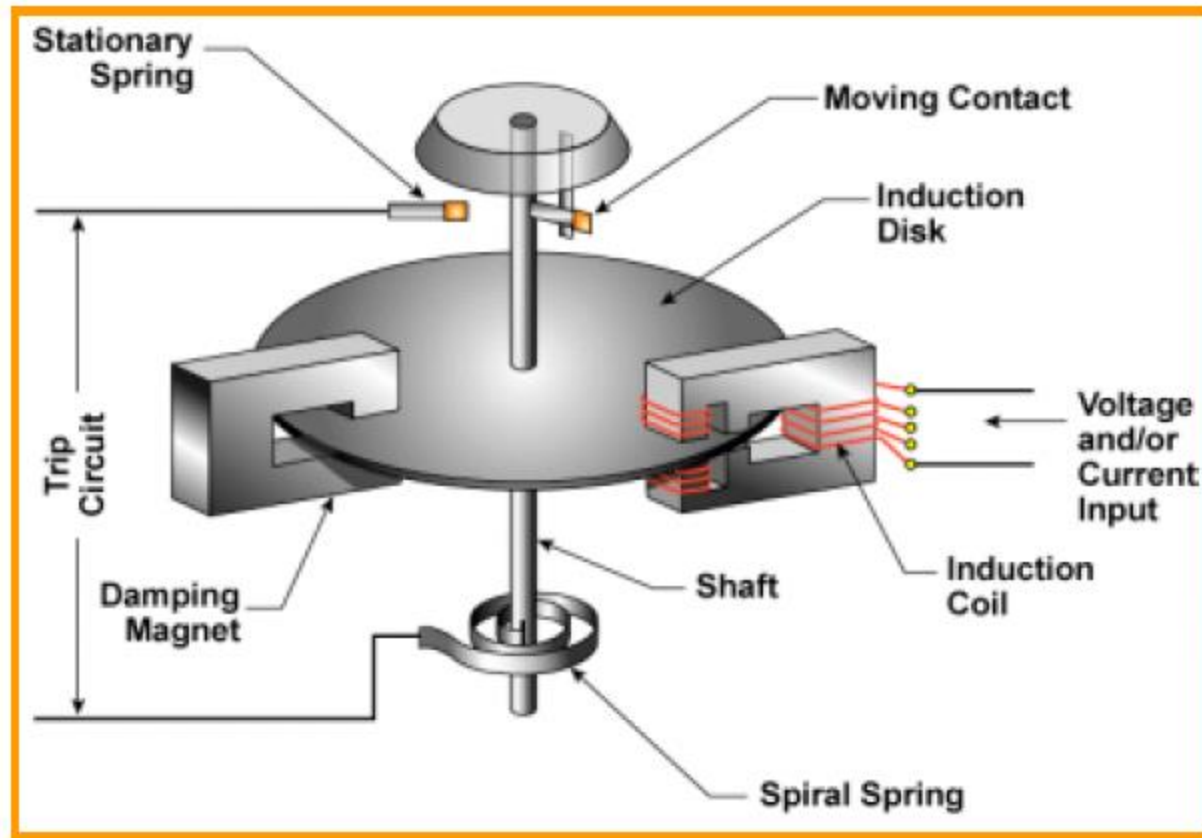

Induction Disc Relay Element

Electromechanical Time Overcurrent

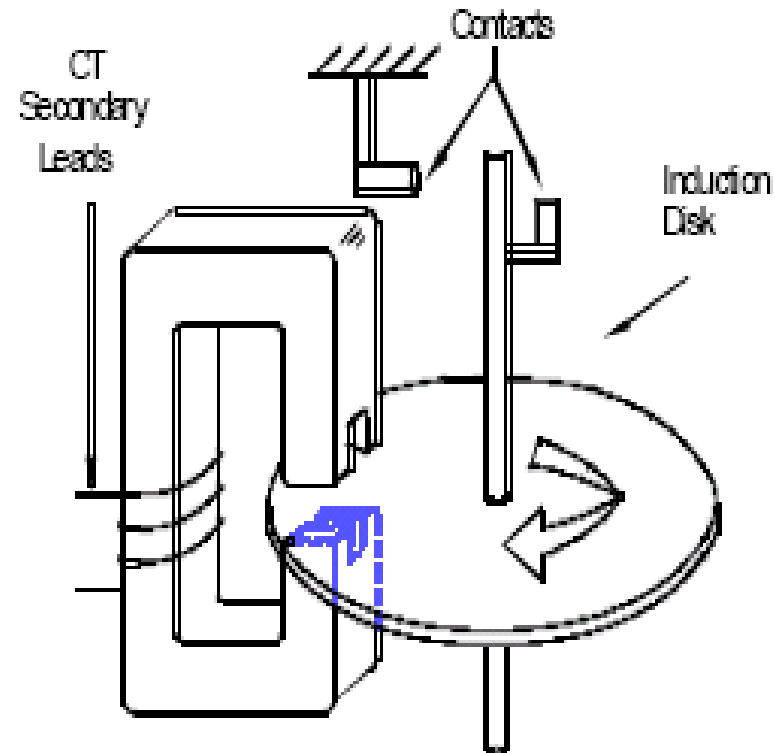

Electromechanical Time Overcurrent

- A **time overcurrent relay (51)** operates if an abnormally high current exists for a predetermined period of time. This relay looks and operates like your household watt-hour meter.
- Currents above a specified minimum operating level, called the ***pickup***, cause the induction disk to rotate. Unlike the disk of a watt-hour meter, the relay's induction disk turns only far enough to close the relay contacts.
- The disk keeps turning as long as the pickup current exists. The greater the current, the faster the disk turns.

Protective Relays

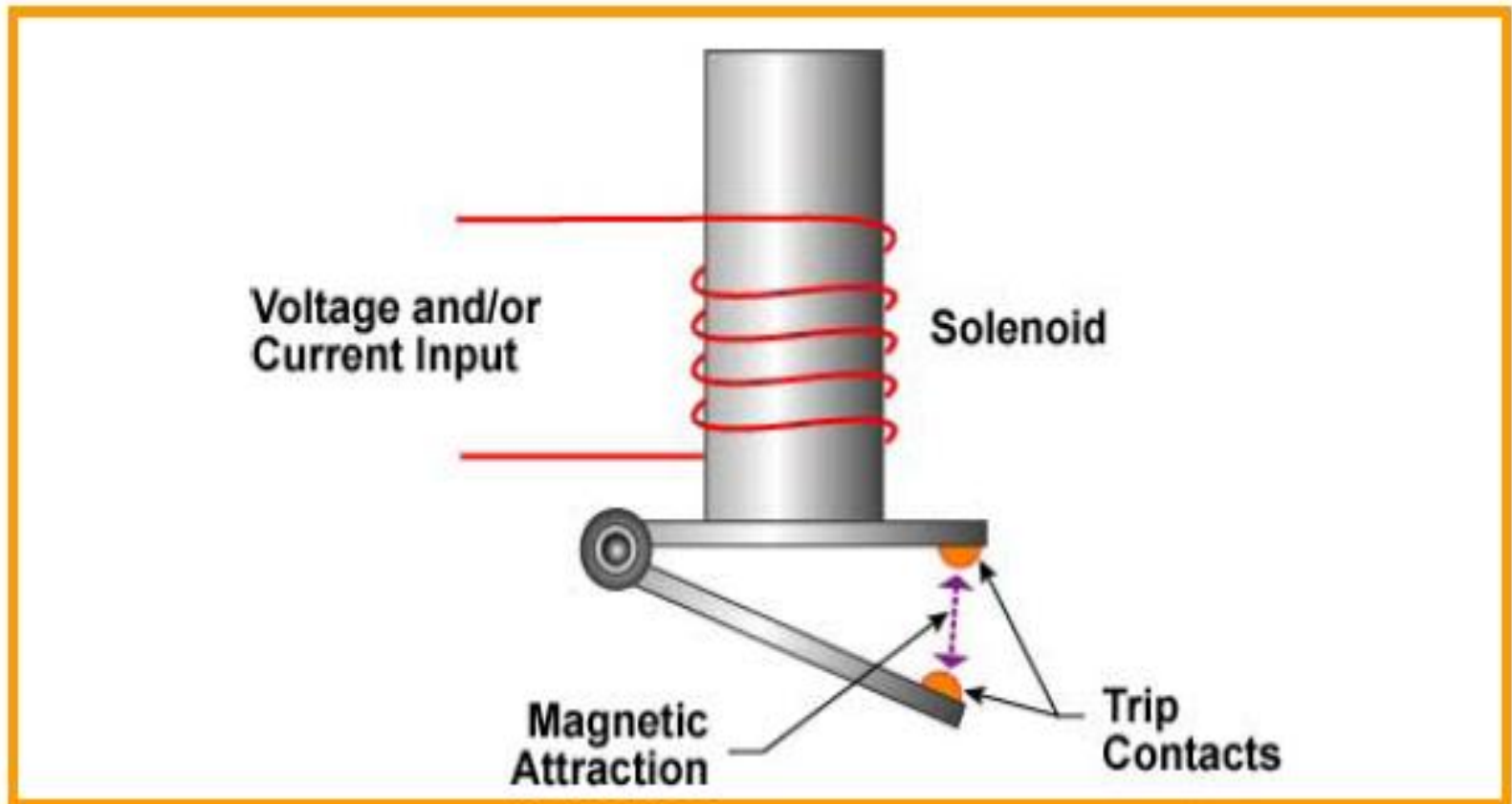

Magnetic Attraction Element for Electro-mechanical Relay

Target

- If the fault stays on long enough, the turning causes the contacts mounted on the disk to touch the contacts mounted on the frame of the relay, completing a trip circuit. An indicator, called a **target**, is displayed when the relay operates. The target remains displayed until it is manually reset.
- If the fault current is removed (cleared) before the trip circuit is completed, the disk stops turning and a spring returns the disk to its starting position.

Targets

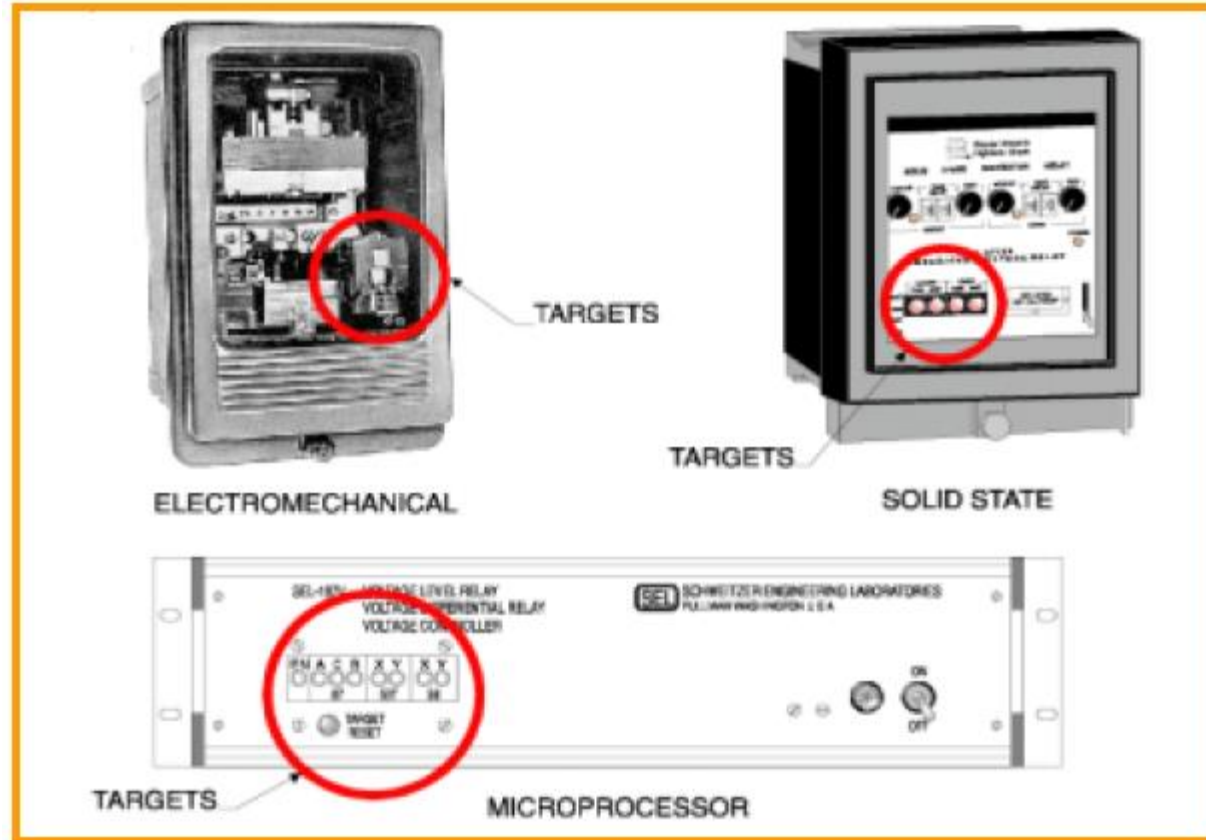

Microprocessor Relays

- Though many utilities continue to use electromechanical relays, manufacturers have introduced new designs. Over the past 20 years or so, utilities have been using "static" relays that are built using transistors and other electronic components.
- More recently, relays which use microprocessors have been introduced.

Microprocessor Relays

- Microprocessor relays are computer-based and have several advantages over the electromechanical and static counterparts, including:
- **Perform Self-Diagnosis:** Microprocessor relays can generate an alarm to warn maintenance personnel that a possible problem exists, so repairs can be performed before the relay is called upon to operate. With electromechanical and static relays, problems are discovered during periodic inspections or when the relays fail to operate when faults occur.
- **Occupy Less Space on Control Panels:** Microprocessor relays typically perform the functions of several traditional relays, and therefore take up less overall space on the control panel.
- **Perform Advanced Functions:** Microprocessor relays can provide information on fault location and can store fault data for analysis.

Control Circuitry

- The third component of the protection system is the control circuitry. The control circuitry includes control wiring, switches, batteries, and other equipment needed to operate substation breakers to isolate the fault.
- The control circuitry is activated after the relays determine that a fault has occurred. The control circuitry sends a signal to the trip coil that opens the appropriate circuit breakers to isolate the faulted equipment from the rest of the power system.

Protection Zones

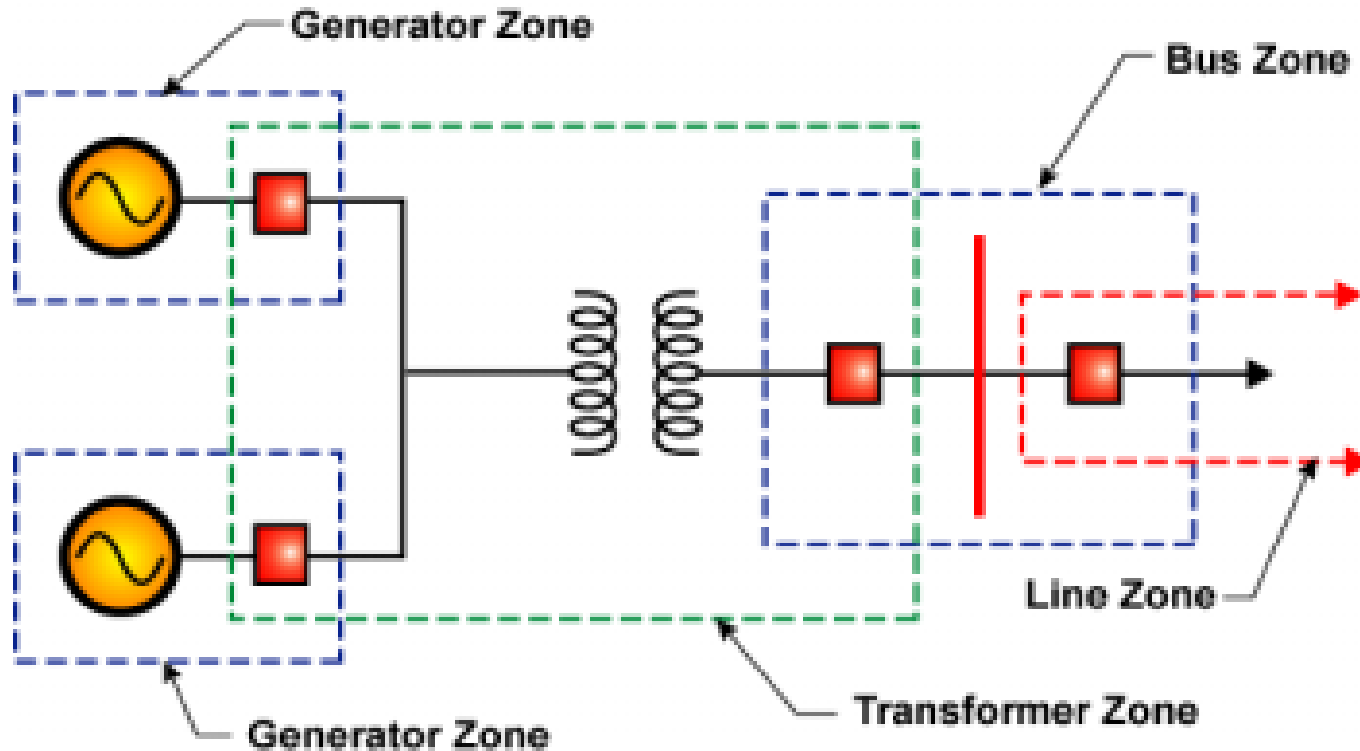

Back Up Protection

- Like any other system, protection systems do occasionally fail to perform. Failure to properly clear a fault is extremely dangerous. (Reasons for avoiding protection system failure are listed in the Purpose section of this module.)
- The protection system's failure to perform may be caused by a malfunction of any of the following:
 - measuring devices
 - relays
 - control circuitry
 - breaker electrical or mechanical components

Types of Relays & Application

- Line Protection Systems
- Substation Equipment Protection Systems
- Generator Protection Systems
- Remedial Action Schemes

Line Protection Systems

- Distribution Feeder
 - Distribution feeders are subjected to a variety of faults, including those due to wind, lightning, tree limbs, and equipment failures.
 - These faults may be transient or may be permanent.
 - If the fault is transient, fast clearing minimizes the damage and may prevent the fault from becoming permanent.

Line Protection Systems

Fuses generally isolate faulted portions of distribution feeders

- The fuse blows:
 - quickly for high currents
 - slowly for low currents

Line Protection Systems

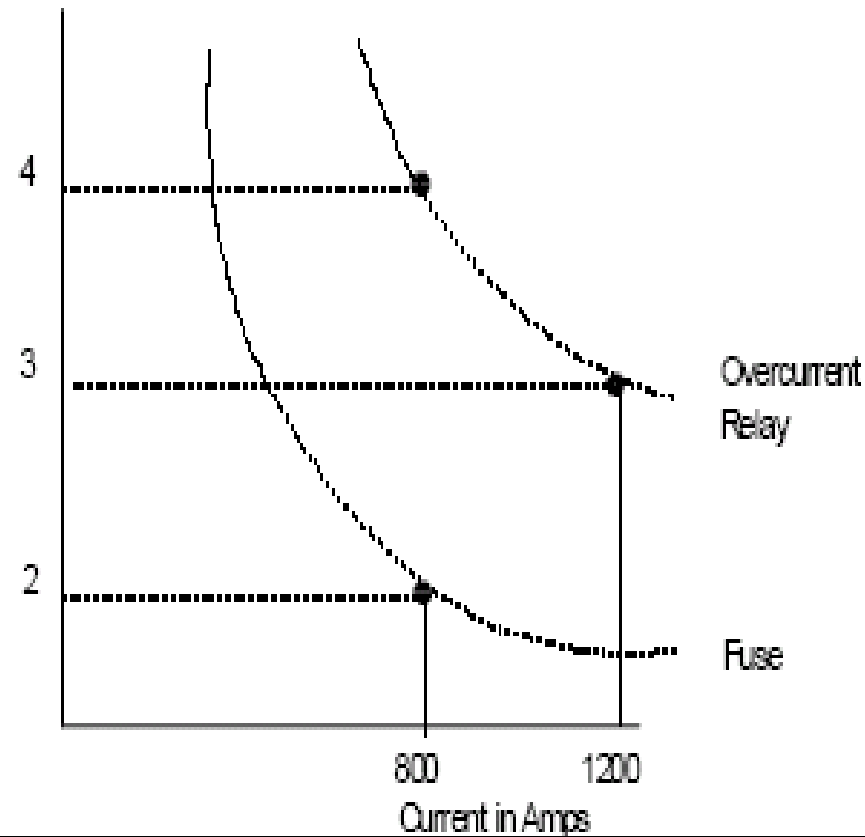

Pickup/Instantaneous Setting

- The minimum current at which the relay operates is called the ***pickup***.
- ***For currents that are just above the pick-up, the time-to-operate is very long. If current is below the pickup, the relay does not operate.***
- ***Instantaneous Setting***
- An ***instantaneous setting*** is a predetermined value of fault current above which some overcurrent relays operate "instantaneously" (with no time delay).

Relay Coordination with Fuses

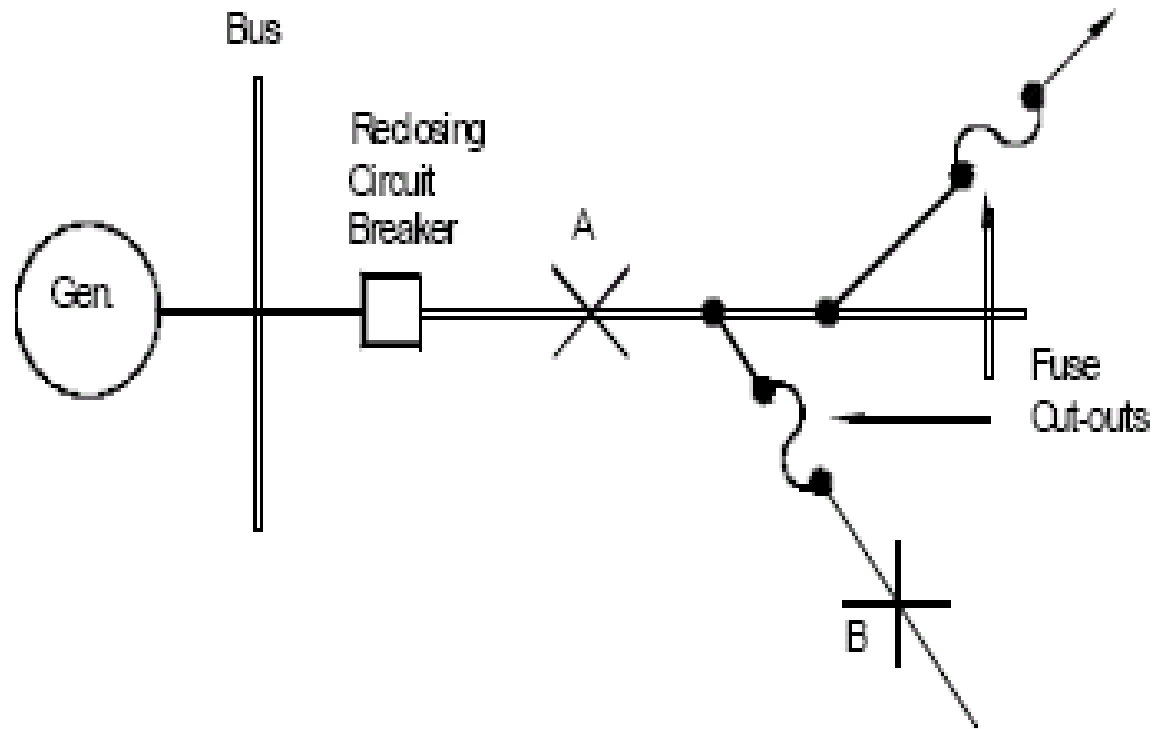

Transmission Line Protection

- Protection systems for transmission lines are usually more complex than distribution line protection systems because of the following features:
 - As part of a power grid, transmission lines connect many generators. Therefore, current can flow in either direction on the line.
 - Faults on adjacent circuits can result in fault current flow in unfaulted lines in either direction.
 - Relaying is required to detect fault location and trip only the faulted line. (The overcurrent relays used for distribution line protection are unable to determine current direction.)

Transmission Line Protection

- The amount of current flow to a transmission line fault depends heavily on the overall condition of the power system (that is, what generators are on-line, what transmission lines are out of service, and so forth). Because the amount of current flow is somewhat unpredictable, overcurrent relay settings would have to be very conservative. This could lead to unnecessary tripping.

Transmission Line Protection

- Fault current levels are usually high on transmission lines. If faults are not cleared rapidly, they can cause system instability, as well as extensive damage to equipment and possible personal hazards.

Types of Transmission Line Protection

- (1) Directional Overcurrent Relaying
- (2) Distance Relaying
- (3) Pilot Schemes
- (4) Out-of-Step Relaying
- (5) Single Pole Relaying

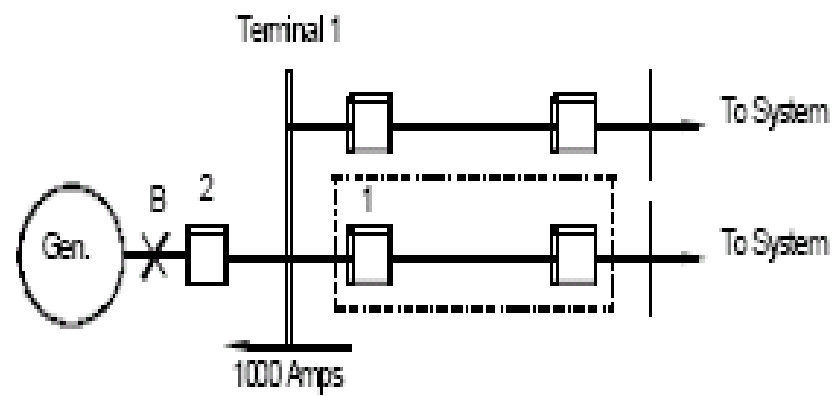
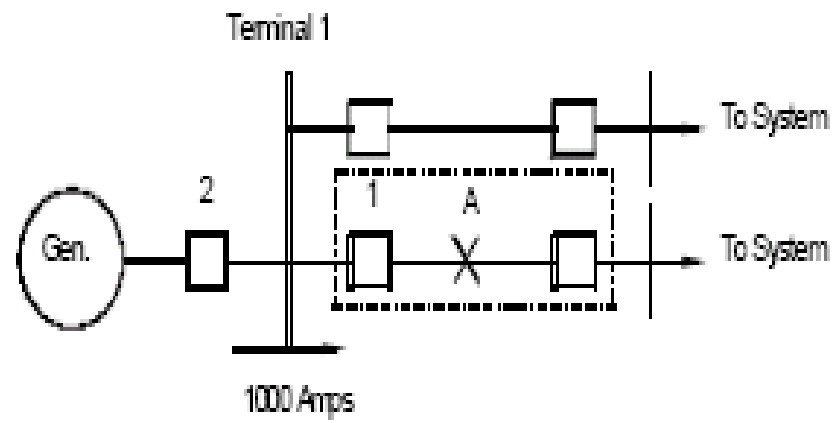

Distance Relaying

- The "distance" in a distance relay refers to electrical distance or impedance. A distance relay monitors the voltage and current, compares the two, and computes Z . If this value is within the pre-set value of Z for the relay, the relay operates.
- Recall from ***Module 2: Fundamentals of Electricity that impedance (Z) is:***

$$Z = \frac{V}{I}$$

Distance Relaying

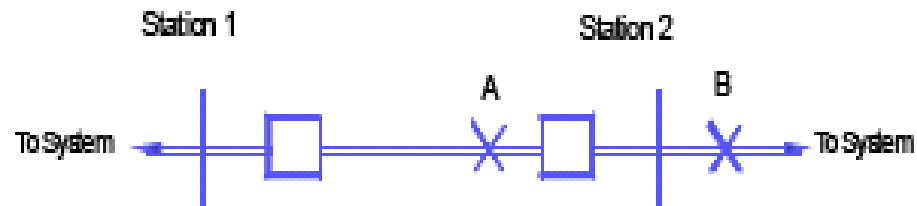

Distance Relaying

- Distance relays may be
 - directional – they detect faults in one direction only
 - non-directional – they detect faults in both directions
- It would be ideal if a distance relay could be set to detect faults all the way to the end of the protected line by setting the trip impedance equal to the line impedance at the far end terminal

Distance Relaying (Zones)

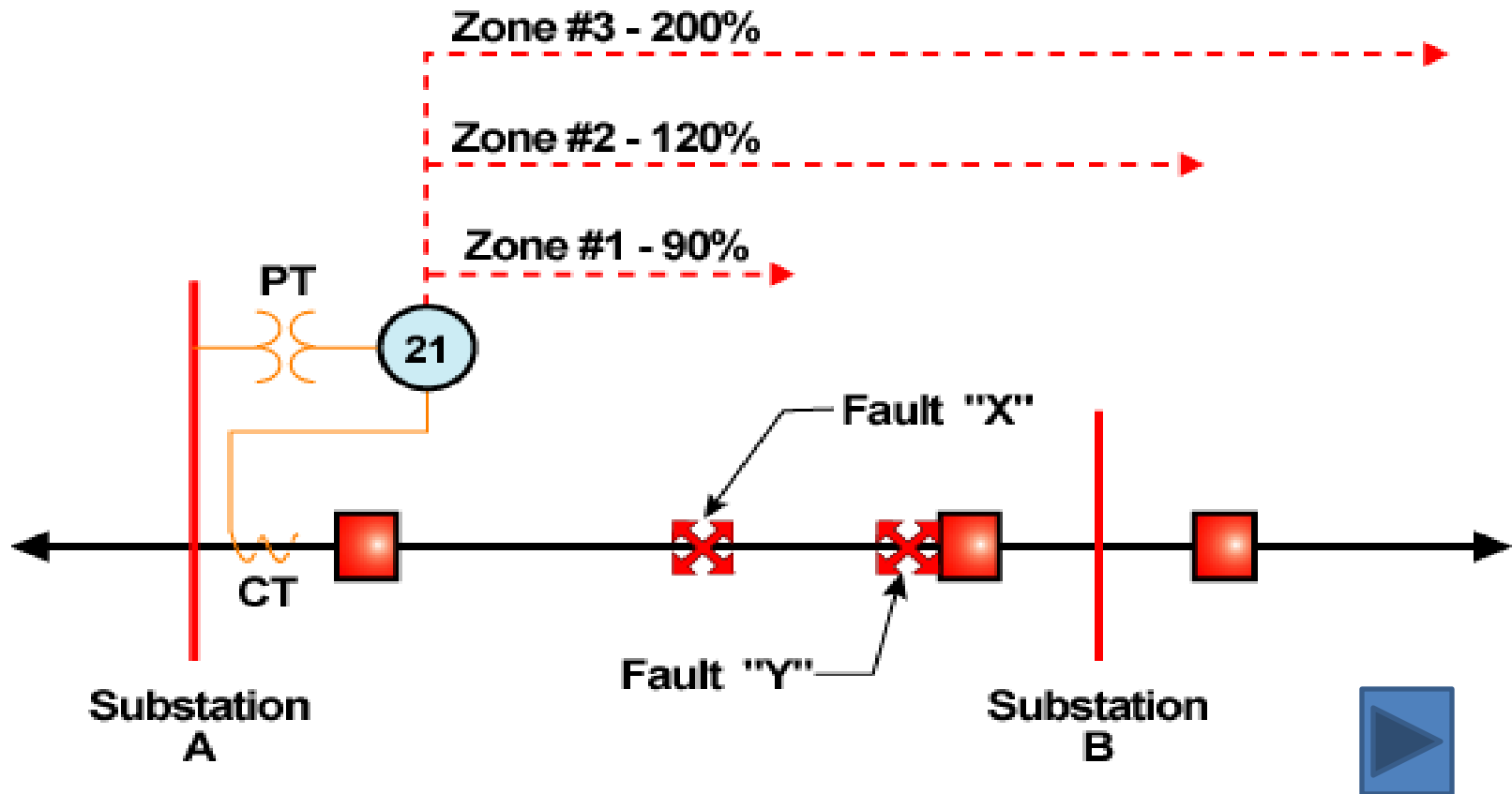

Pilot Schemes

- To provide high-speed tripping for end-zone faults (beyond Zone 1's reach) on a transmission line section, we must provide some form of communication channel between the line section terminals.
- A communication or "pilot" channel provides this capability. It allows the relays to compare fault conditions at the line terminals to determine whether the fault is internal or external to the protected zone.

Pilot Schemes

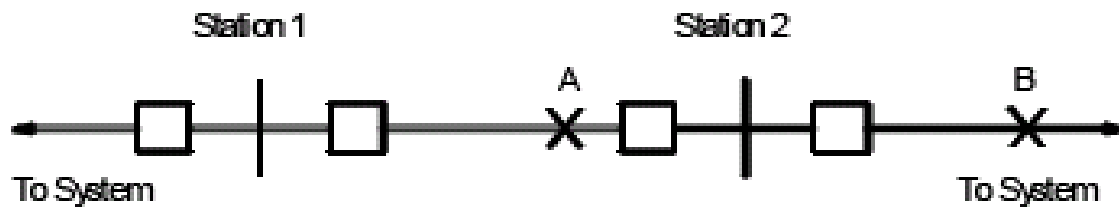

Transfer Tripping
Directional Comparison
Phase Comparison
Pilot-Wire



DISTANCE RELAYING

ZONE 1

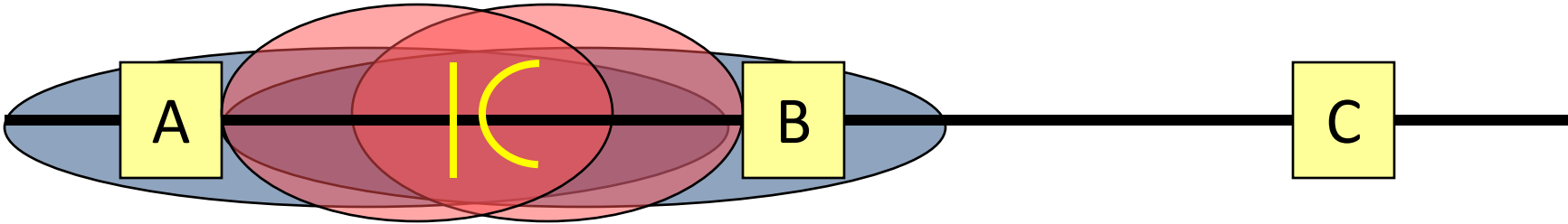

ZONE 2

DISTANCE RELAYING

ZONE 1

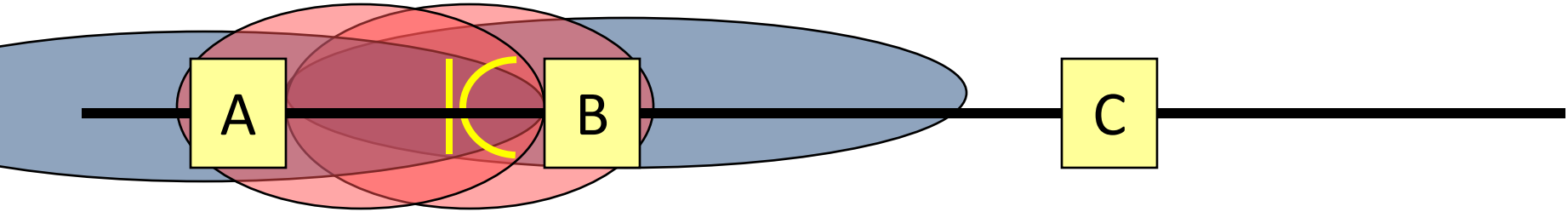

ZONE 2

DISTANCE RELAYING

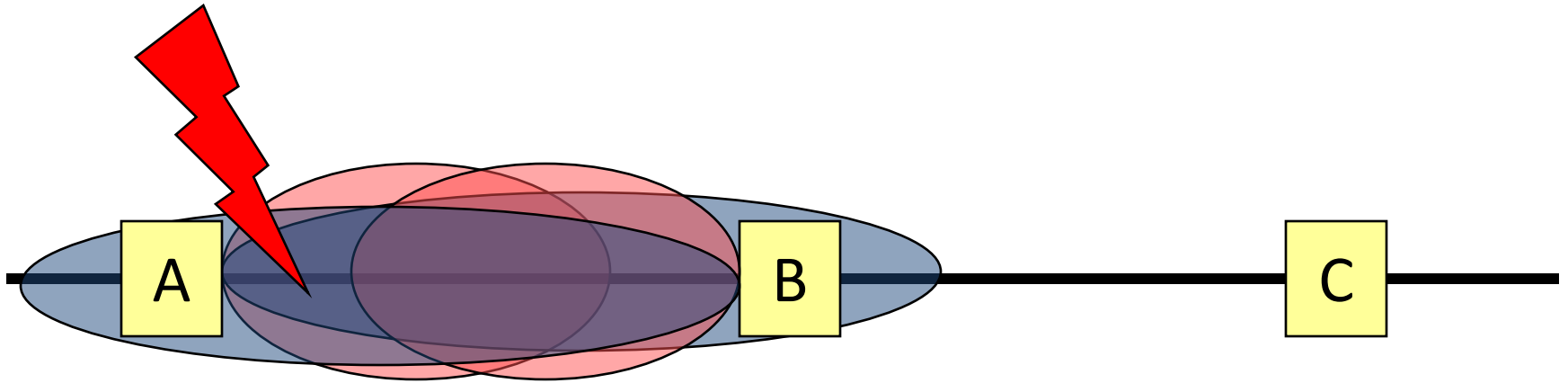

What the targets tell you about location of the fault

Directional Comparison

- Another variation of the pilot scheme is the directional comparison scheme.
- In this scenario, fault-detecting directional distance relays at each line terminal determine the direction of the fault current and compare their individual results over the pilot or communication channel.

Directional Comparison

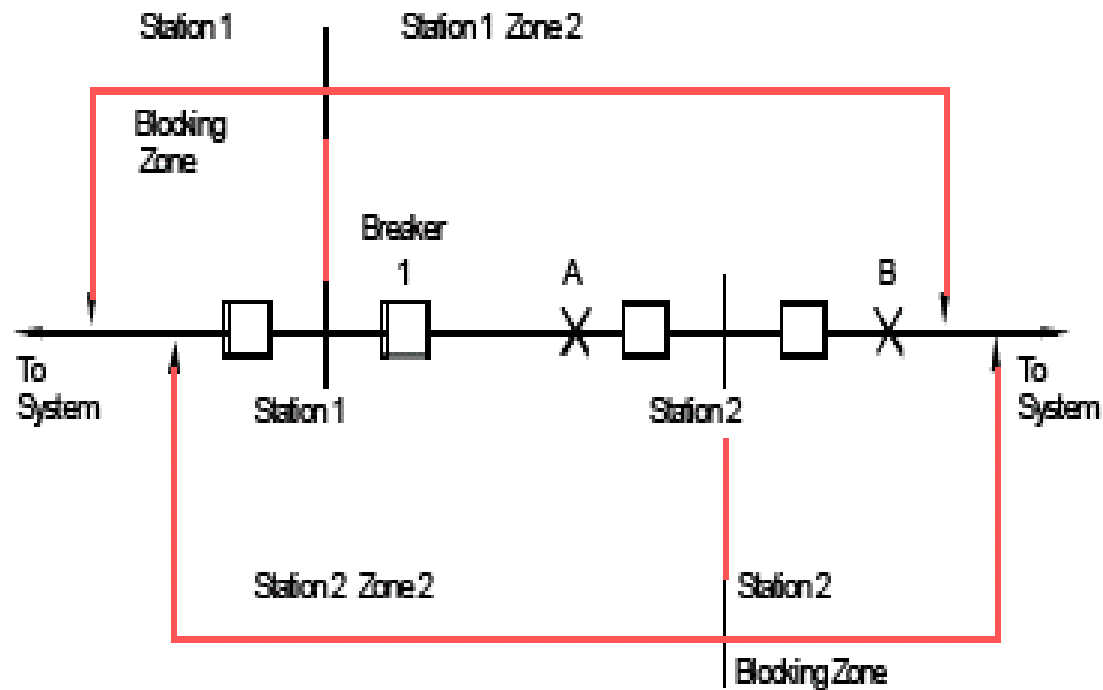

Phase Comparison

- Phase comparison systems, another variation of the pilot scheme, use overcurrent fault detecting relays to compare the relative phase angles of the currents at the two terminals via the communication channel.

PHASE COMPARISON RELAYING

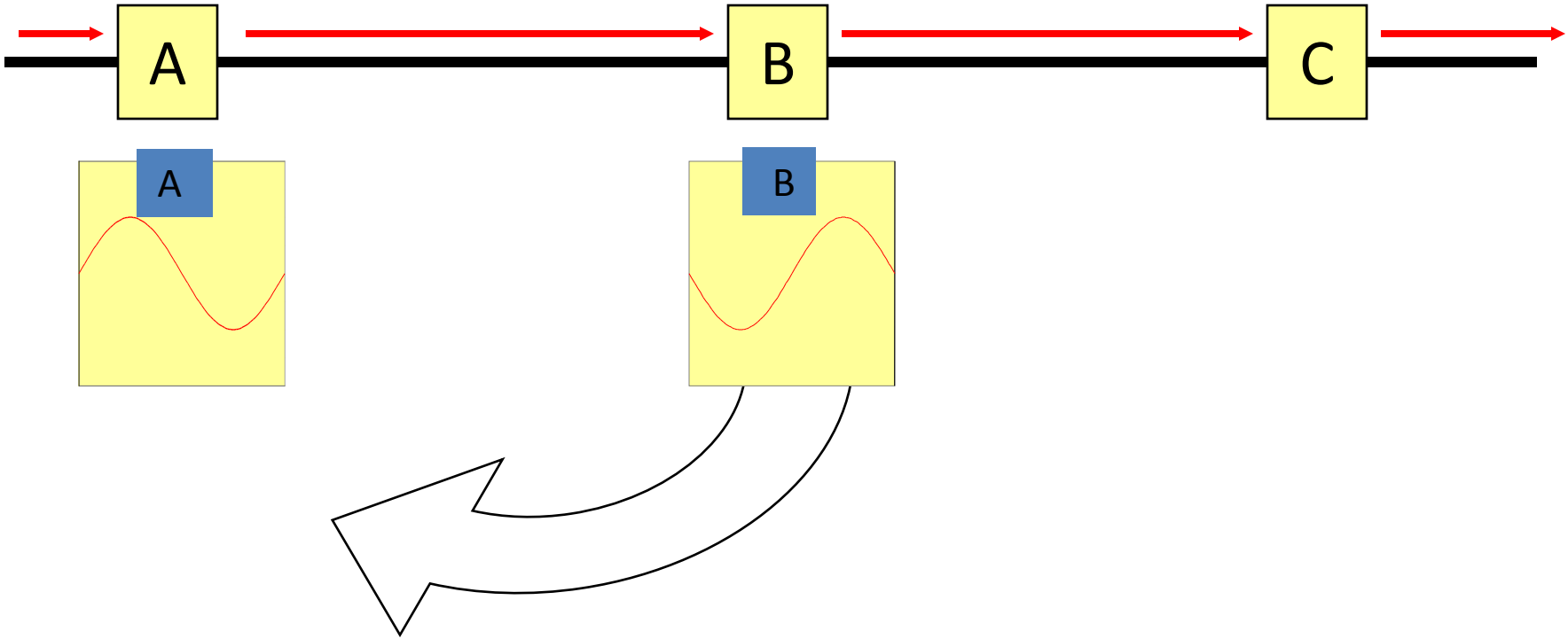

PHASE COMPARISON RELAYING

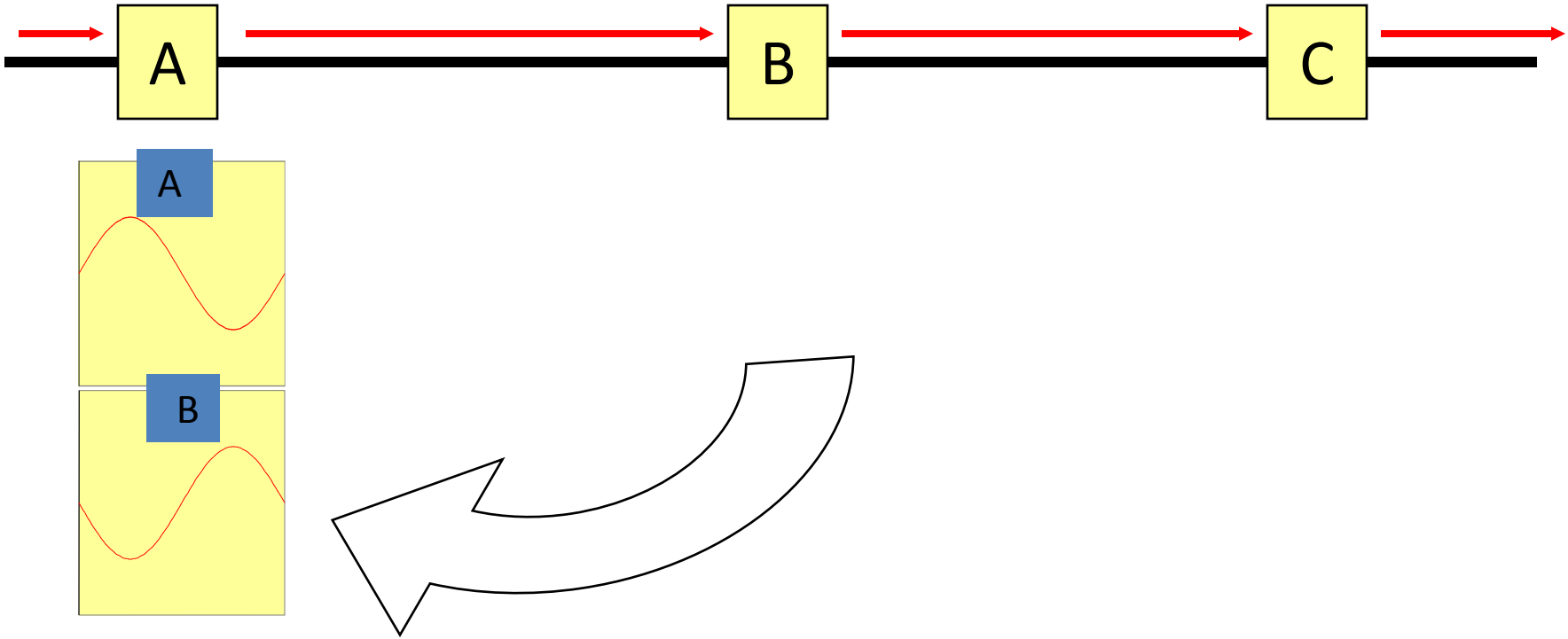

PHASE COMPARISON RELAYING

→ CURRENT FLOW →

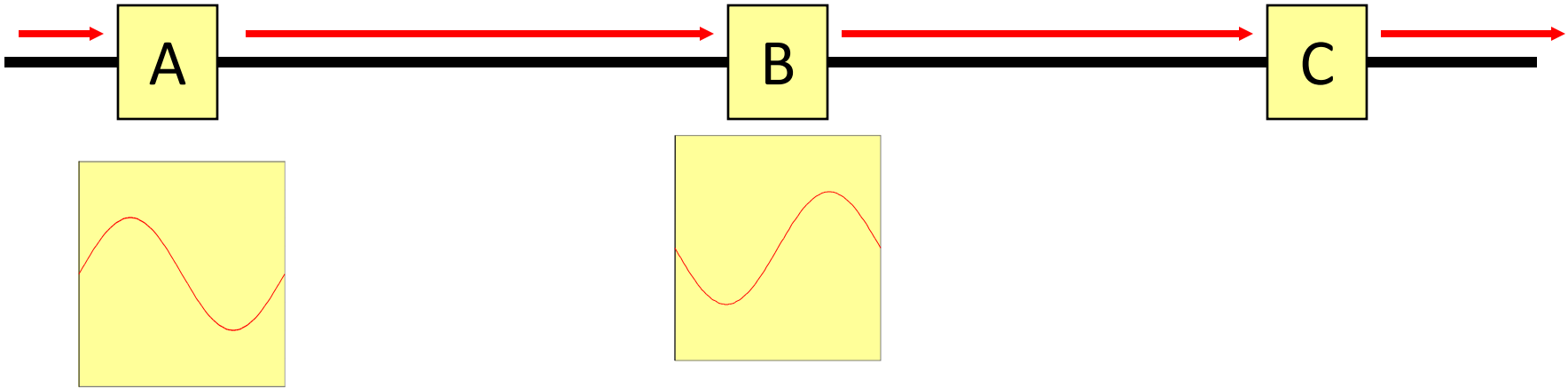

PHASE COMPARISON RELAYING

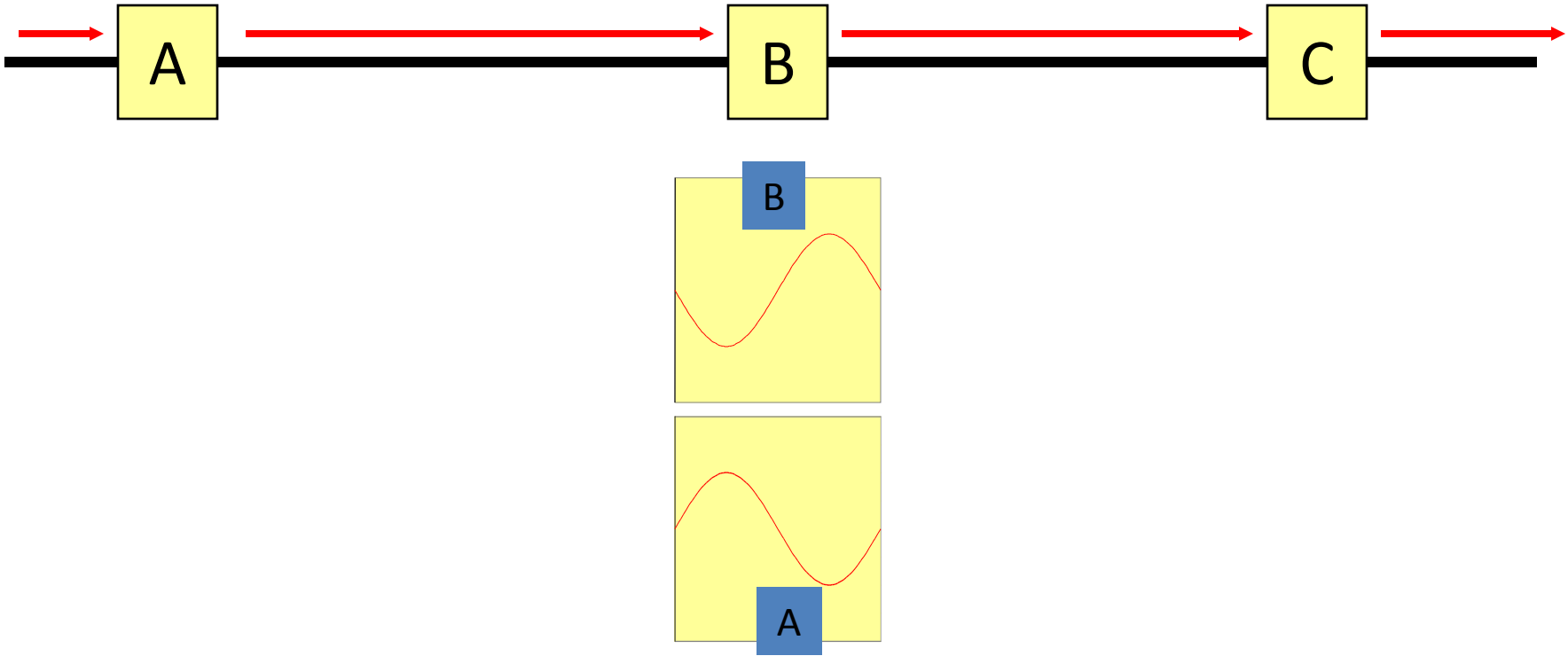

PHASE COMPARISON RELAYING

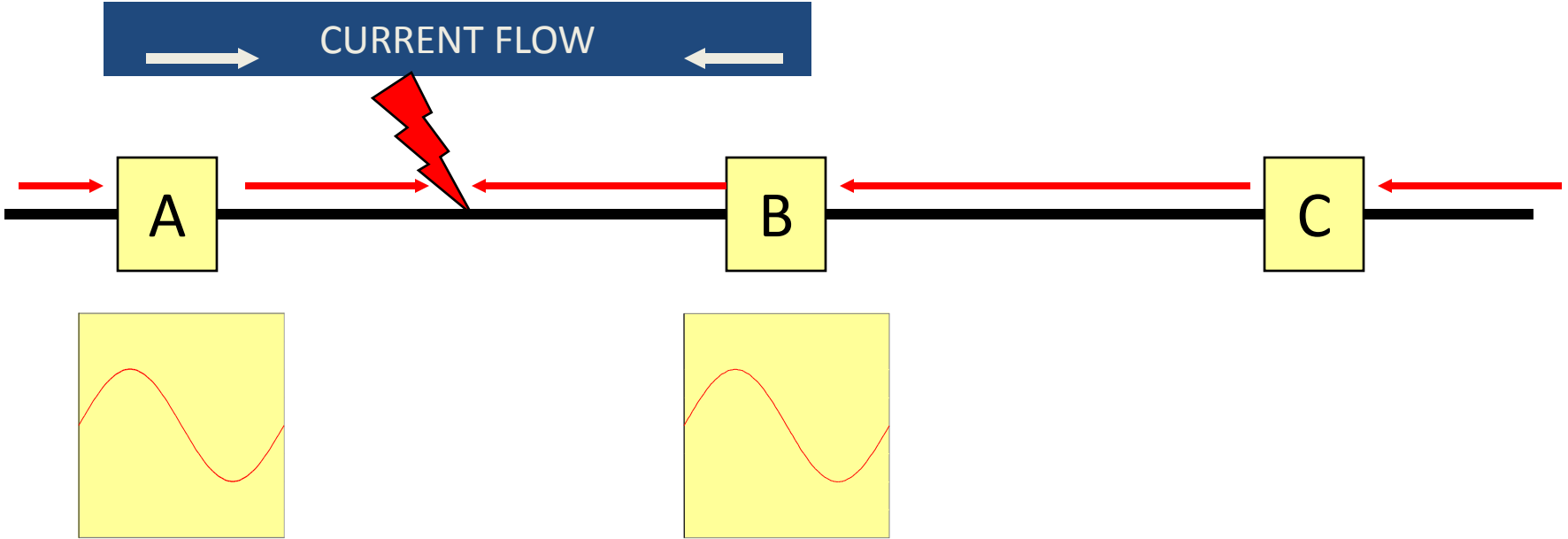

PHASE COMPARISON RELAYING

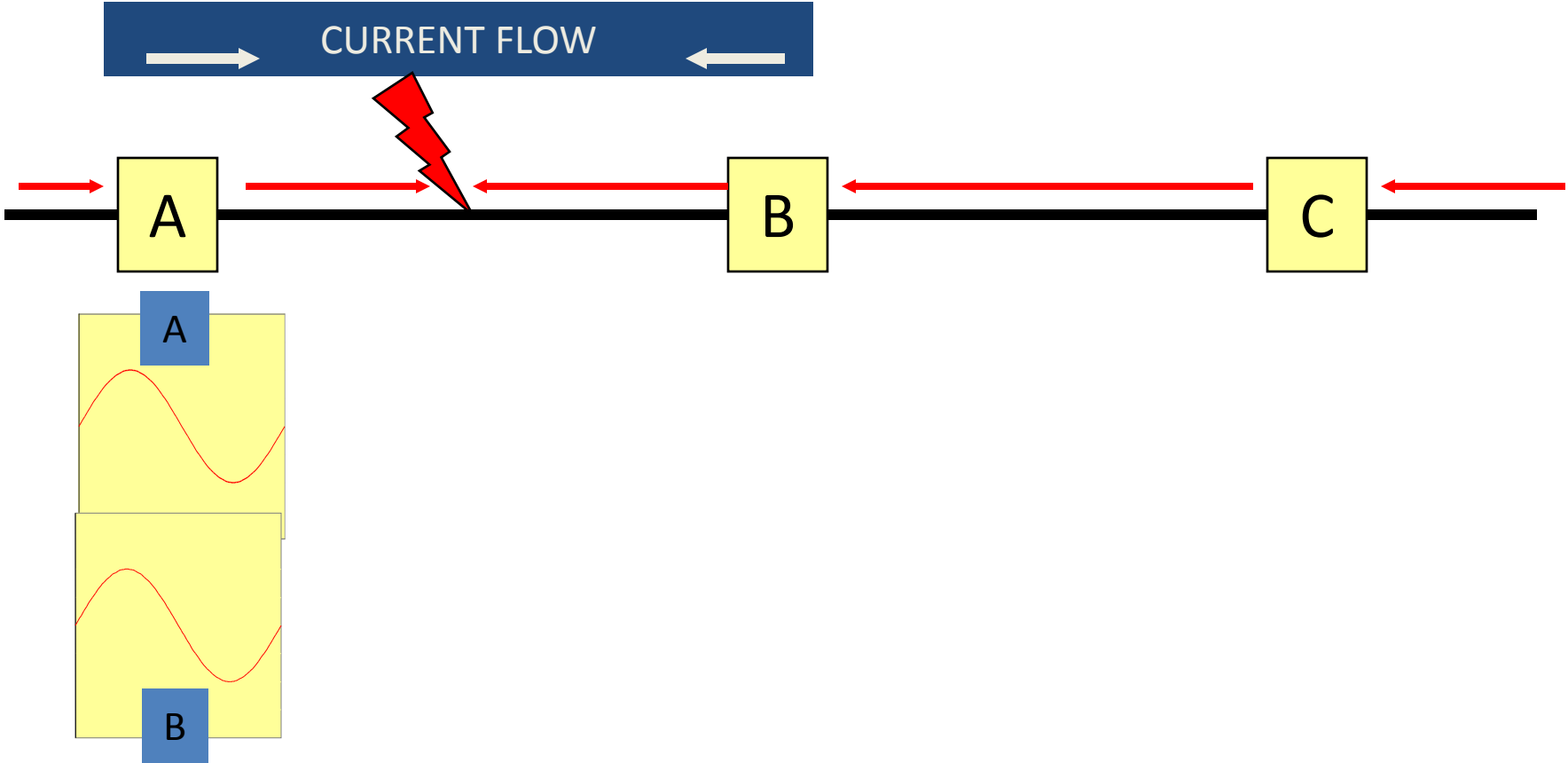

PHASE COMPARISON RELAYING

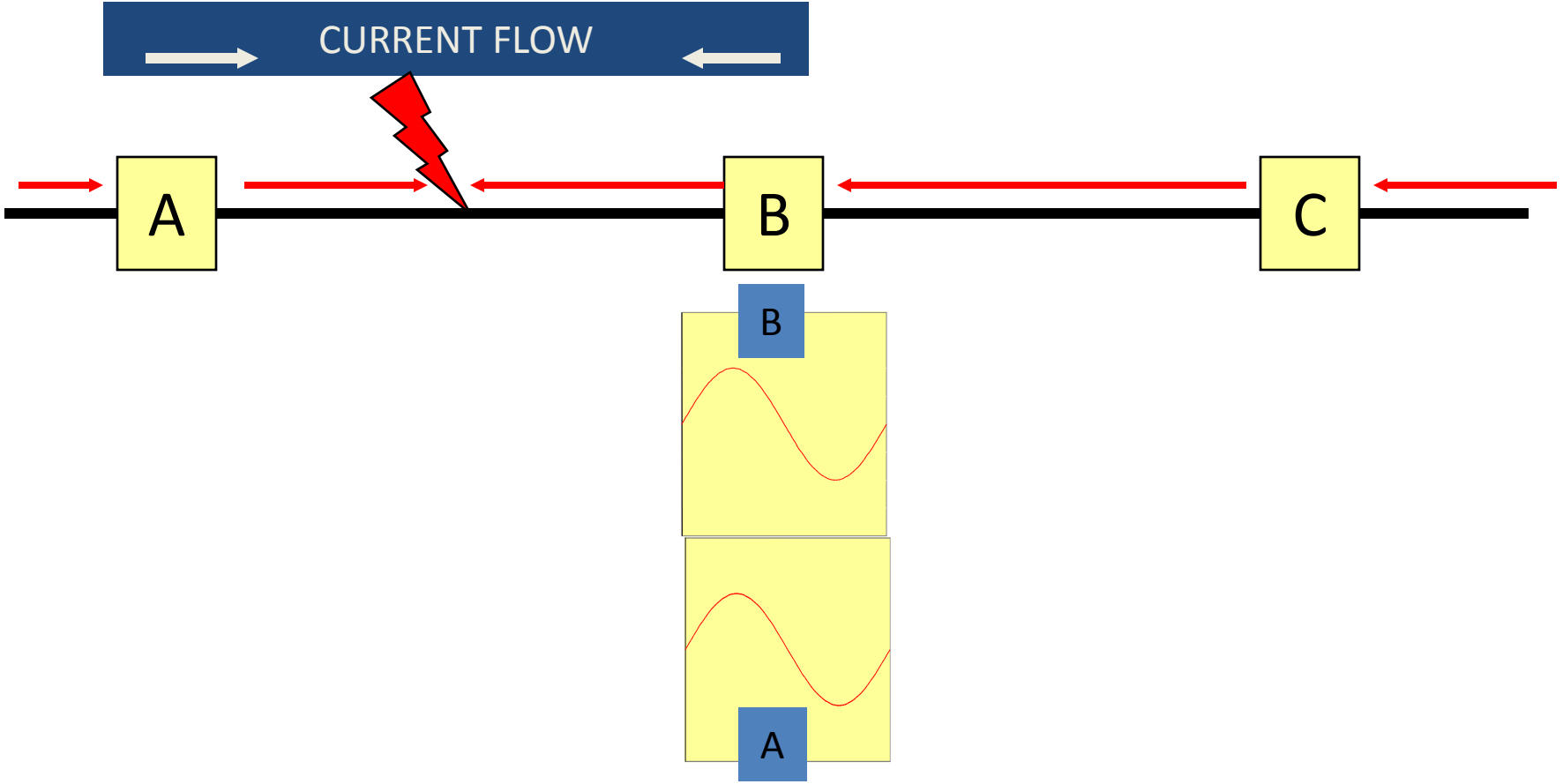

Pilot Wire

- Another commonly-used type of pilot protection system is the pilot wire relay system.
- This system compares the magnitude and phase angle of the current flowing at each end of the line to determine whether an internal fault exists.

PILOT WIRE RELAYING

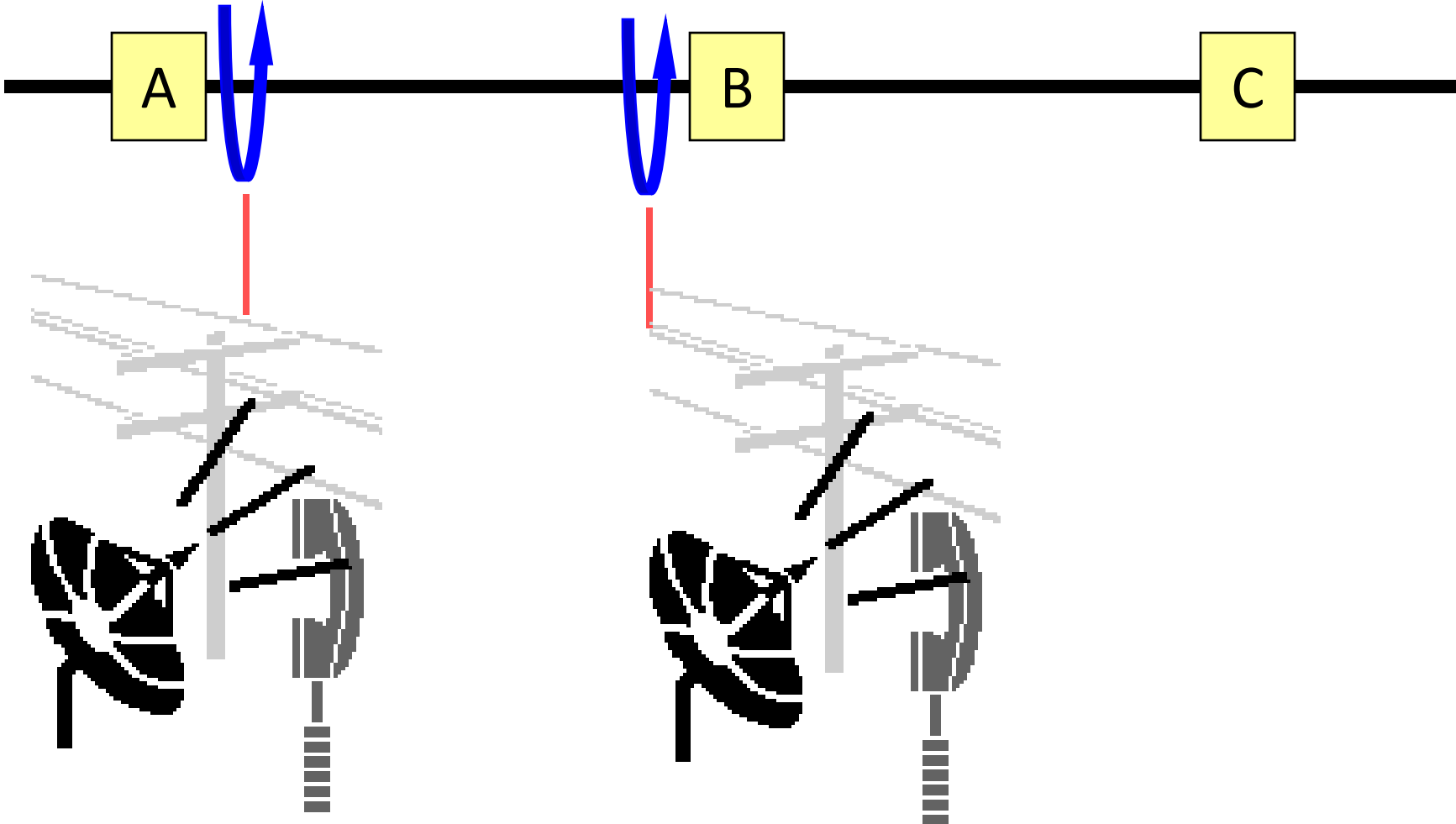

Out-of-Step

- **Definition: Swings**
- Protection systems must function properly during power system "swings".
- **Swings** are oscillations of generators with respect to other generators due to sudden changes of load, switching, or faults.
- To function properly, out-of-step (OOS) protection systems must be able to:
 - trip for non-recoverable stability conditions and true faults
 - block tripping for recoverable swings

How Out-of-Step Works

- If the impedance decreases suddenly to the relay's trip setting, a true fault has likely occurred. Therefore, tripping is required.
- If the impedance decreases gradually to the relay's trip setting, this most likely is due to swinging generators rather than a fault in the relay's protected zone. Therefore, the relay holds off tripping until it determines whether the system can recover from the swing.

How Out-of-Step Works

- If the impedance returns to normal within a pre-determined time period, the relay assumes that the system has recovered and no tripping occurs.
- If the impedance stays low for a specified time period and then gradually moves above the trip setting, the system is probably unstable, so tripping occurs.

Single Pole Relaying

- **Definition: Single Pole Tripping**
- Most transmission line faults are temporary single-phase-to-ground faults.
- They can be cleared by opening and reclosing only the faulted phase.
- This method is known as ***single pole tripping***. It leaves the other two phases intact and minimizes the shock to the power system.

SINGLE POLE TRIPPING

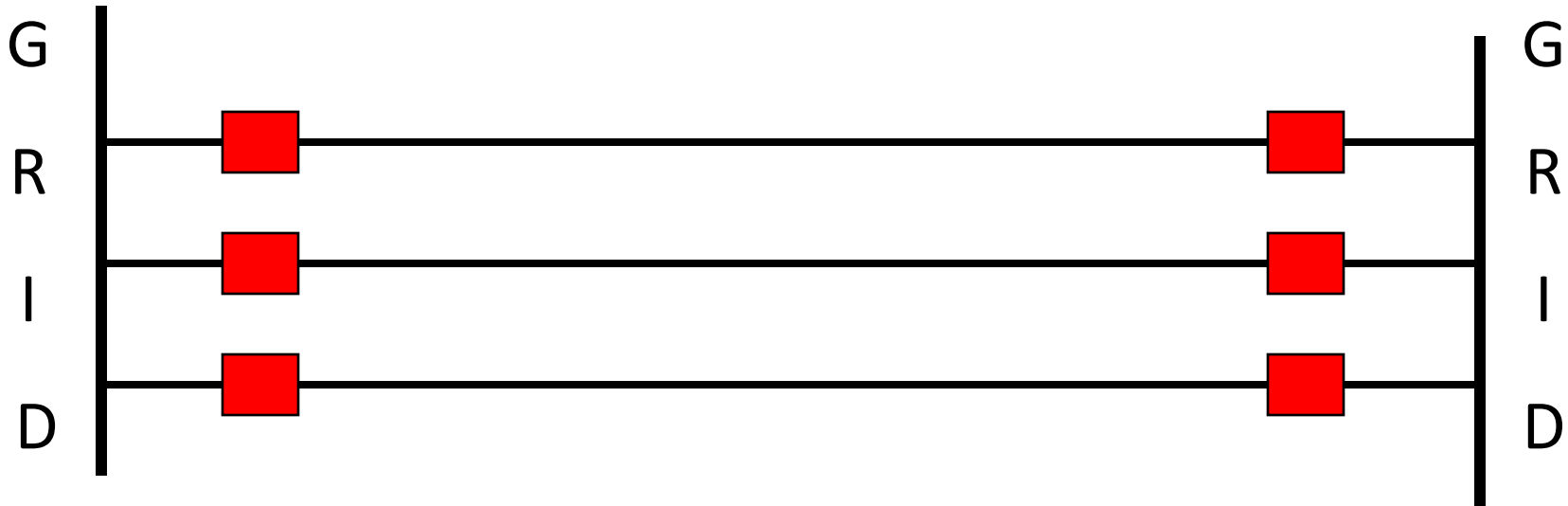

SINGLE POLE TRIPPING

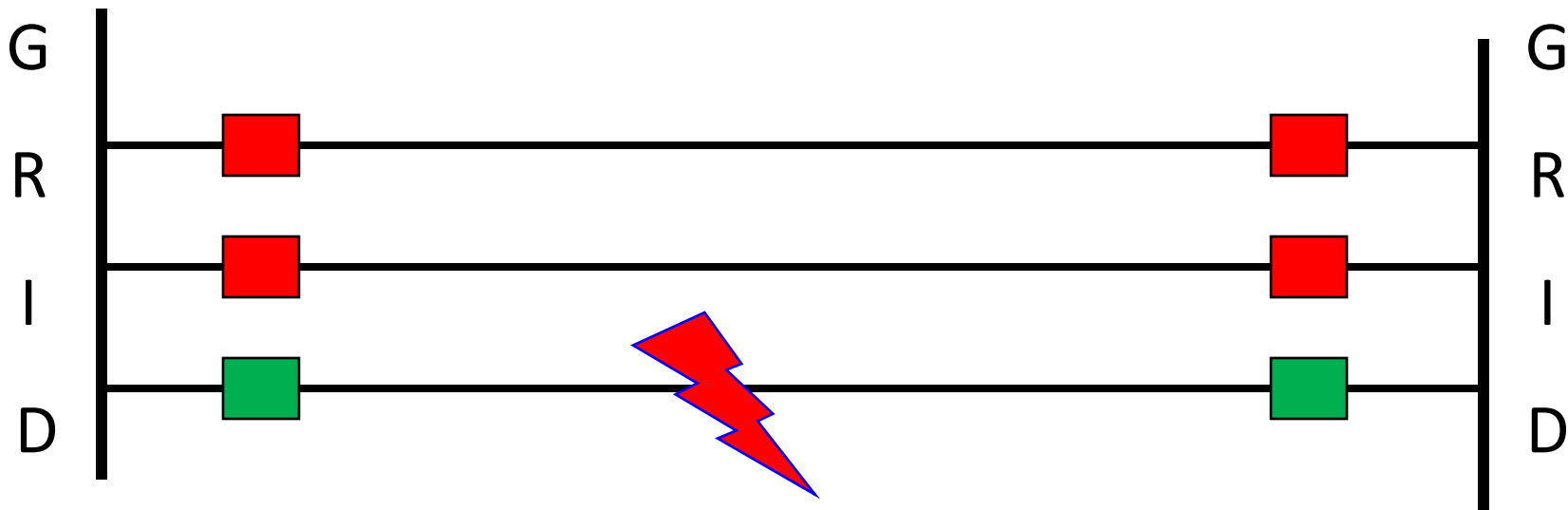

SINGLE POLE TRIPPING

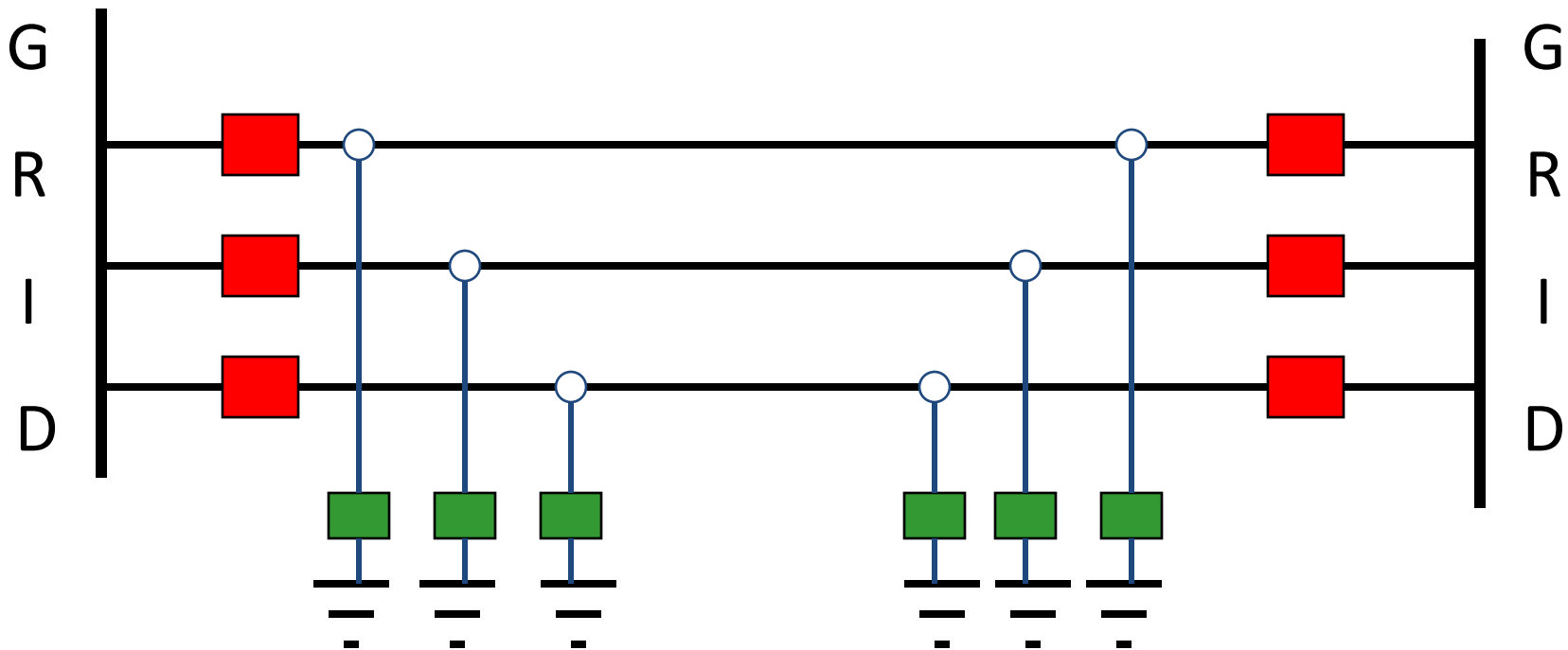

SINGLE POLE TRIPPING

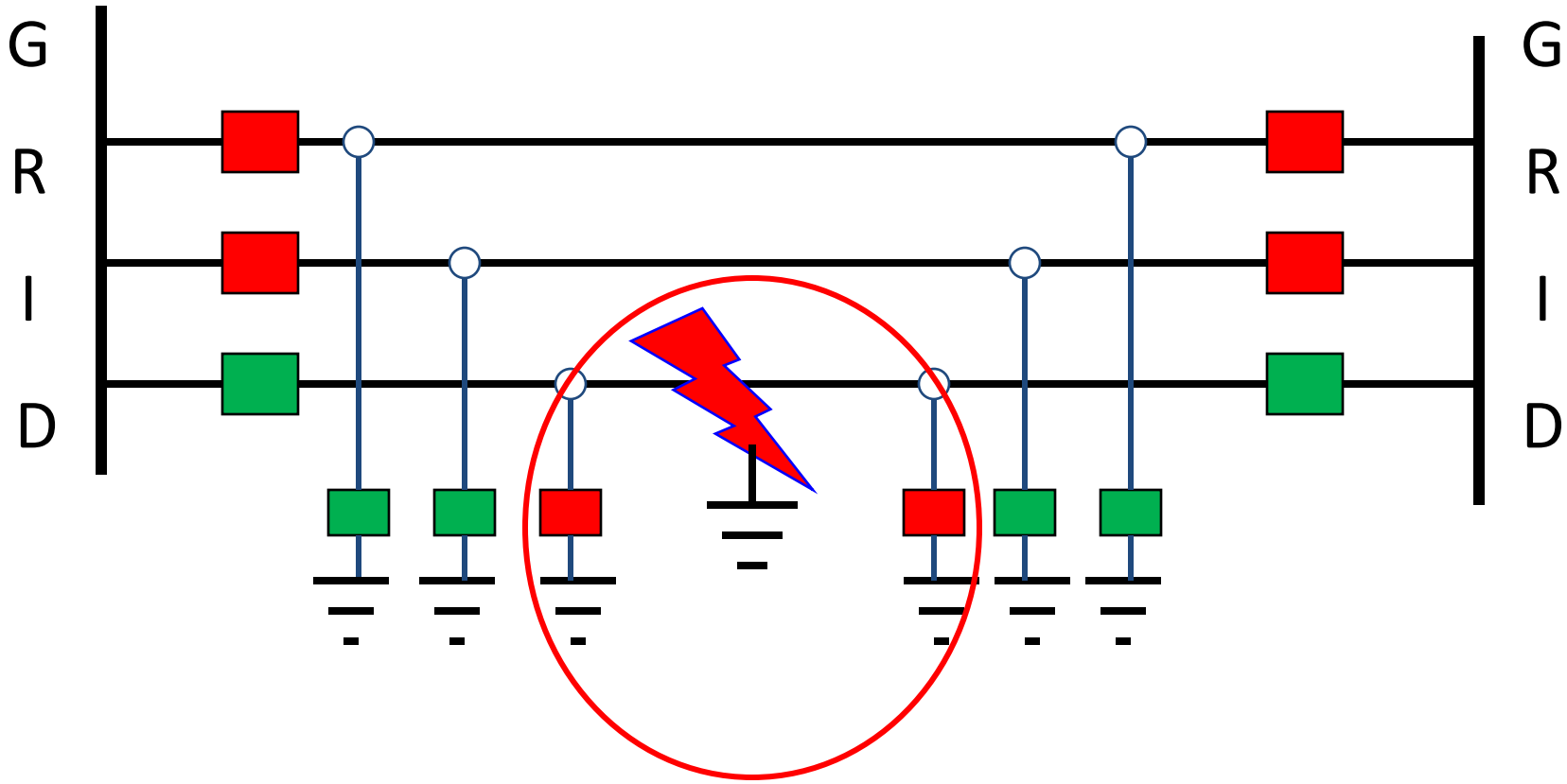

SINGLE POLE TRIPPING

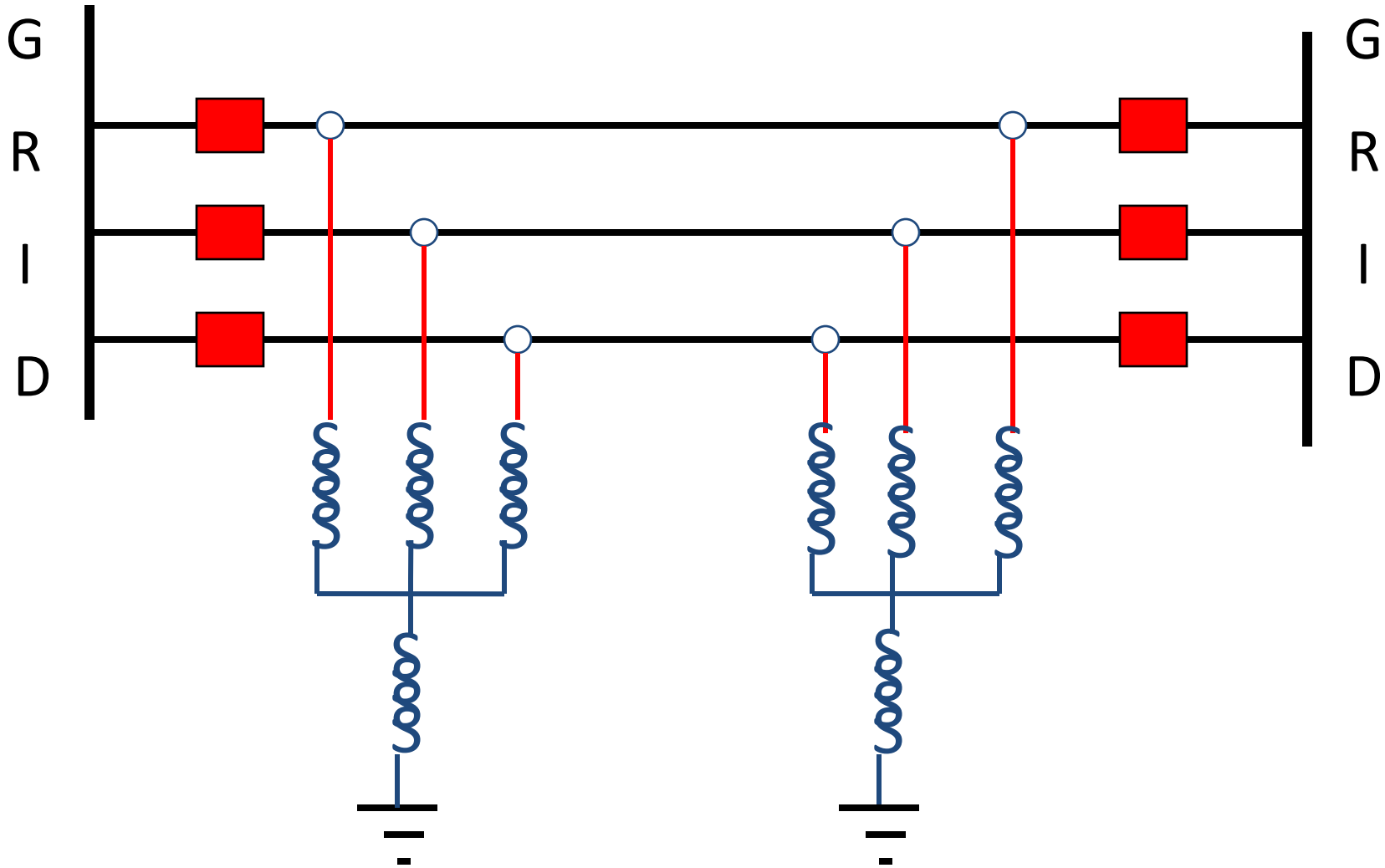

SINGLE POLE TRIPPING

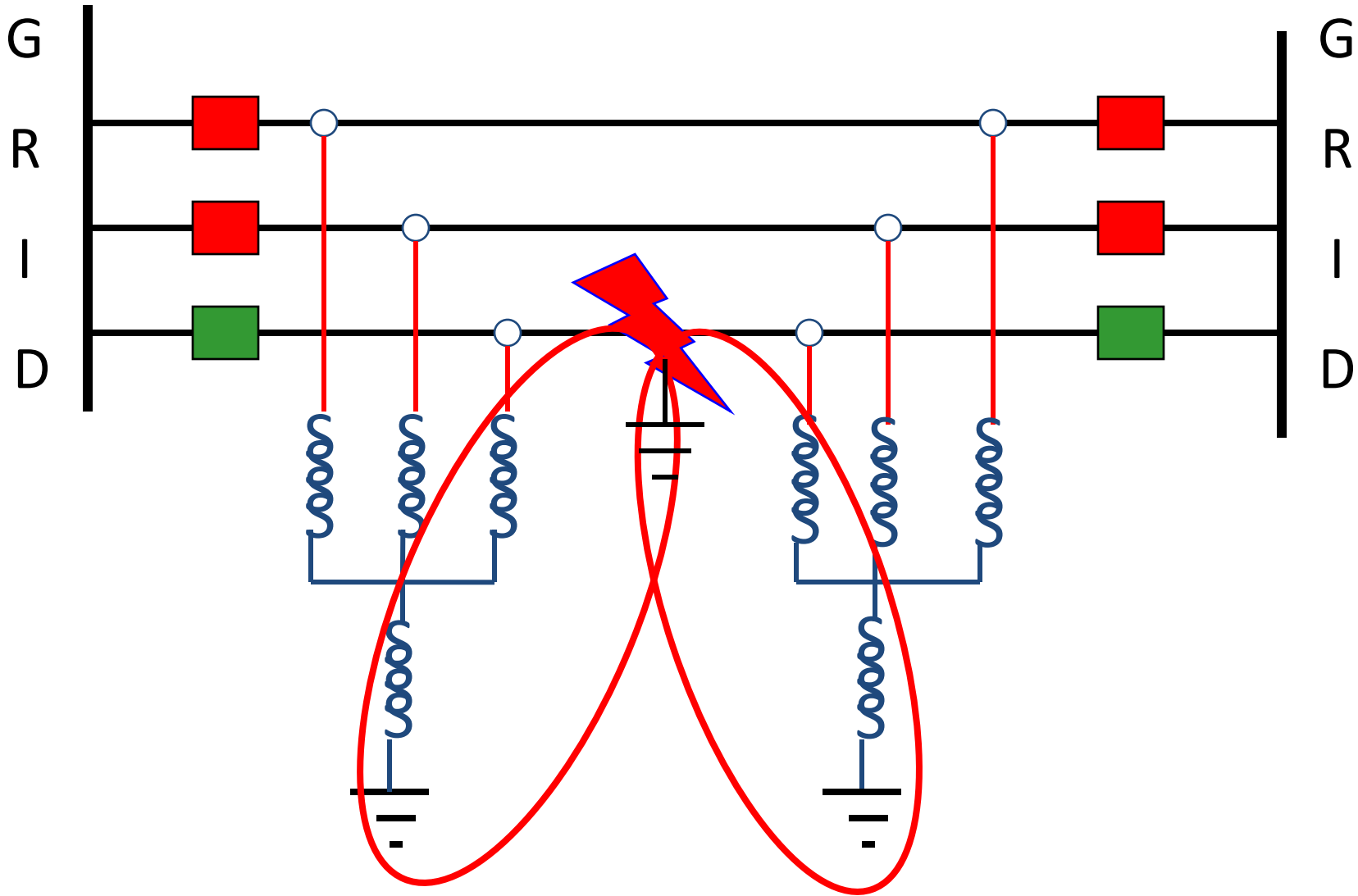

Relay Types - Practice

http://bsc-noudini.bsc.nodak.edu/onlinepres/ILTs/Transmission_Line_Relaying.swf

Transmission Line Protection: Instructions Version

This simulation demonstrates the operation of different transmission line protection packages. Clicking on the online diagram will initiate a fault. Click reset to clear the fault and reset the relays.

BSC BISMARCK STATE COLLEGE
National Energy Center of Excellence

Line 1 Relays

INST	TIME	COMM	SOTF	1	2	3	Distance:
●	●	●	●	●	●	●	0 Miles
TRIP				ZONE			

Line 1 Length 200 Miles

Distance Relay (21)

Substation A Bus A Line A

Substation B Bus B Line B

Simulation Controls

Reset Pause Change Relay Package

Instructor Mode

● Off ○ On

Line A Relays Bus A Relays

Line B Relays Bus B Relays

CYCLETIMER

Substation Equipment Protection

- Shunt Equipment Protection
- Bus Protection
- Transformer Protection
- Circuit Breaker Failure Protection
- Underfrequency Load Shedding

Shunt Equipment Protection

- Shunt equipment, such as a capacitor bank, is usually protected using:
 - Time overcurrent or differential relays which open circuit breakers or circuit switchers to de-energize this equipment during a fault.
- Or
 - Fuses that blow to de-energize the device when high current flow occurs.

Bus Protection

- Substation buses usually have one or more incoming lines that are sources of fault current, and multiple outgoing lines, that may or may not be sources of fault current.

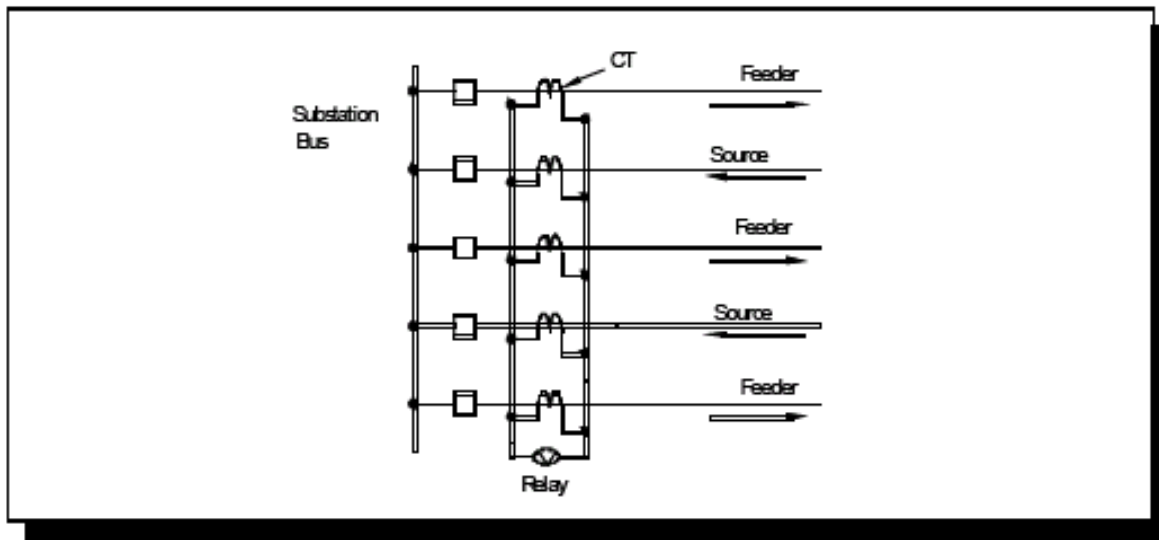

Bus Protection

- Differential protection is the most sensitive and reliable method for protecting substation buses, because:
 - all currents entering and leaving the bus are added
 - the difference between the incoming and outgoing currents is the input to a sensitive overcurrent relay.

Transformer Protection

- The most common forms of protection systems for substation transformers are overcurrent, differential and sudden pressure detection.
- Transformer overcurrent and differential protection systems are similar in concept to the previously discussed applications, in that:
 - Transformer overcurrent relays detect abnormally high current flow to the transformer.
 - Transformer differential relays subtract the current leaving the transformer from the current entering the transformer, and then use the difference current to determine if an internal fault exists.

Transformer Protection

- However, both of these schemes are complicated by magnetizing in-rush current flow to the transformer.
- When a transformer is first energized, a transient magnetizing or exciting current may flow.
- In-rush current can reach peak values of up to 30 times the full-load value, which is more than enough to cause an overcurrent relay to operate.

Harmonics

- To prevent overcurrent and differential relays from operating on inrush current, we must use special relays with reduced sensitivity to inrush currents.
- Typically, such relays filter out the harmonic content of the current before deciding whether a fault exists.
- ***Harmonics are electric currents that alternate at a frequency other than 60 Hz.***
- In some cases, the harmonic portion of the current restrains the operation of the relay until the inrush currents decay (die out) to an insignificantly small value.

Transformer Sudden Pressure

- Transformer sudden pressure relays operate if the gas pressure in the transformer abruptly rises to a certain level.
- Sudden pressure increases indicate a fault.
- Transformer gas usually results when "arcing" from internal faults breaks down the transformer's insulating oil.

Breaker Failure Protection

- Problems can occur which prevent a circuit breaker from operating when called upon by a protection system.
- Faults that are not cleared by the primary protection system and associated circuit breakers almost always will eventually be cleared by protection systems in adjacent protection zones.
- But the delay in clearing the fault can be intolerable on high-voltage facilities.

Breaker Failure Protection

- Circuit breakers at important high-voltage facilities are frequently equipped with circuit-breaker-failure detection circuitry.



Underfrequency Load Shedding

- In a stable power system, the generator control systems usually maintain system frequency very close to 60 Hz.
- Sudden or large changes in generating capacity due to the loss of a large generator or tie-line can cause a severe generation/load imbalance, resulting in a frequency decline.

Generator Protection

- Although the frequency of generator faults is low, the potential for severe damage and consequently long outages is high.
- Therefore, some of the most complex and sensitive protection systems are used for the generators.

Generator Protection

- Some of the most common methods of detecting faults in generators are:
 - Winding Differential Protection
 - Ground Fault Protection
 - Detection of Unbalanced Faults
 - Overload Protection
 - Loss-of-Excitation Protection
 - Generator Motoring Protection
 - Generator Protection at Reduced Frequencies

Winding Differential

- With the winding differential protection scheme, the currents in each phase on each side of the machine are compared in a differential circuit.
- Any significant difference in current is interpreted as some form of fault and the relay operates.

Ground Fault Protection

- It is difficult to detect small generator ground faults before they become big ones. Current-type relays are generally inadequate for detecting generator ground faults.
- It is more common for the protection system to measure the voltage of the generator neutral with respect to ground.
- A sensitive over-voltage relay is connected across the resistor of the generator neutral.
- A ground fault anywhere in the generator's protection zone causes a voltage to appear across the neutral resistor, operating the relay to trip the generator.

Detection of Unbalanced Faults

- We know from ***Module 2: Fundamentals of Electricity***, that electric power systems are three-phase and normally balanced on all phases.
- Sometimes abnormal conditions exist on parts of the system causing unbalanced conditions. These include:
 - single phase-to-ground faults
 - line-to-line faults
 - unbalanced voltages
 - open circuits

Detection of Unbalanced Faults

- To protect the generator from damage caused by unbalanced faults, a relay system called negative phase sequence (unbalance) relaying is used to sense the condition and trip the machine.



Overload Protection

- Most large generators are equipped with resistance temperature detectors (RTDs) that detect overheating due to overload.
- Typically, the outputs from this RTD drive a warning light to inform the plant operator of the potential overload conditions.
- The RTD may also be used to provide a trip signal.

Loss-of-Excitation

- Recall from ***Module 4: Principles of Power Generation***, that the function of the generator excitation system is to provide direct current for the generator rotor windings (field windings). The generator excitation system:
 - maintains generator voltage
 - controls reactive power flow
 - assists in maintaining power system stability

Generator Motoring

- If an undetected prime mover problem occurs (e.g., low steam or water flow), the input to the turbine may be too low to meet all the losses in the generator.
- The turbine compensates for this deficiency by absorbing real power from the power system.
- Now, the machine is performing in a manner similar to a synchronous motor.
- A protection system that detects reverse power flow (into the machine) identifies generator motoring.

Generator Protection at Reduced Frequencies

Under-Frequency Limit (Hz)	Over-Frequency Limits (Hz)	Time Delay Before Tripping
60.0-59.5	60.0-60.5	NA (Normal)
59.4-58.5	60.6-61.5	3 minutes
58.4-57.9	61.6-61.7	30 seconds
57.8-57.4		7.5 seconds
57.3-56.9		45 cycles
56.8-56.5		7.2 cycles
<56.4	>61.7	Instantaneous Trip

Remedial Action Schemes

- Remedial action schemes (RAS), also called special protection systems, initiate actions to prevent power system instability and equipment overloads if critical network elements are lost.
- Remedial action scheme requirements are unique for each power system.
- These protection schemes typically result from engineering studies that identify potential system "weak" spots if certain contingencies occur.
- A contingency is the loss of one or more power system elements, such as a transmission line, transformer, or generator.

Remedial Action Schemes

- The types of functions performed by remedial action schemes include:
 - tripping selected generating units
 - inserting capacitors or dynamic braking resistors
 - shedding load
 - tripping selected transmission lines

Remedial Action Schemes

- These functions are performed to prevent overloading lines and losing critical facilities.

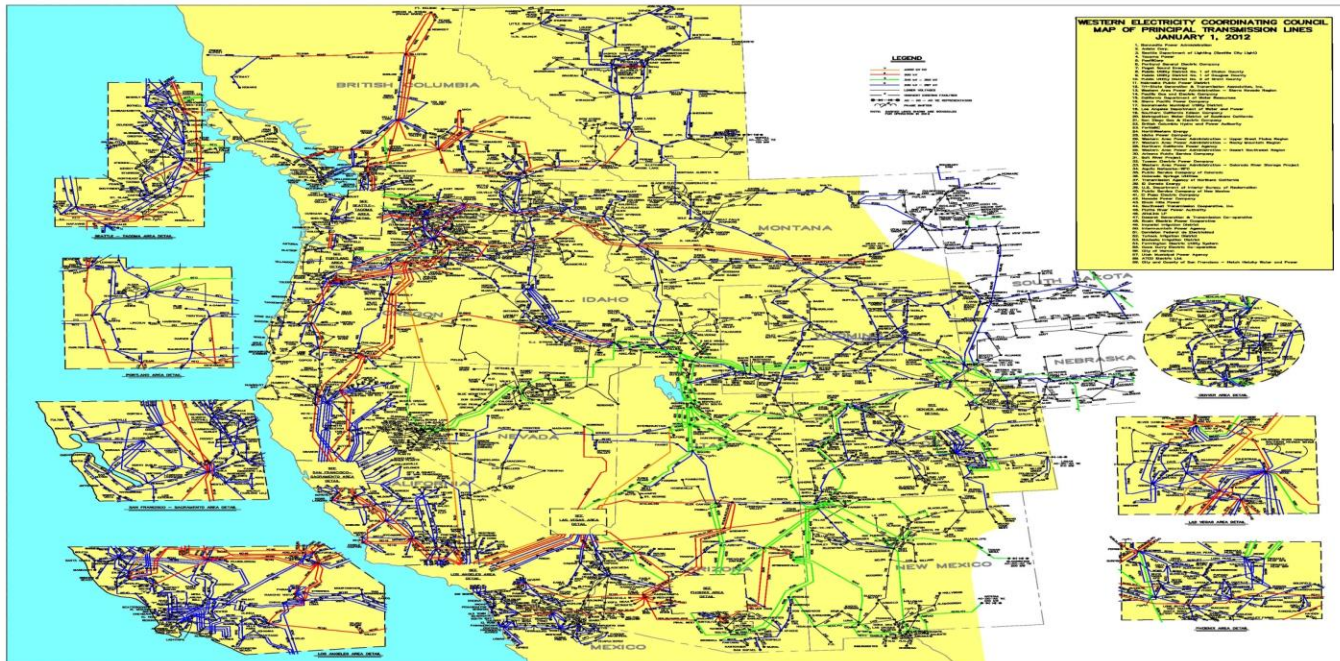

Causes of protection system failures

- The relays are only as good as the system they are connected to.
- The biggest causes of protection system failure are:
 1. Instrument transformer failure -
 - a. CTs, PTs, CCVTs, CCPDs, etc fail
 2. Protective Relay Misoperation
 3. Control Circuitry failure.
 - a. Open in control circuitry (open trip coil, mice/rat chew through wires, etc.)

Questions?

